

# GRANDE

*By*   
Balkania Ceramics  
[www.balkaniaceramics.com](http://www.balkaniaceramics.com)

GRANDE

*By*   
Balkania Ceramics  
[www.balkaniaceramics.com](http://www.balkaniaceramics.com)

# 120X280

01 SHIRA BLACK POLIRANA	007
02 SHIRA BLACK SATIN	007
03 MARSHALL WHITE POLIRANA	009
04 MARSHALL WHITE SATIN	009
05 MARSHALL GOLD POLIRANA	011
06 MARSHALL GOLD SATIN	011
07 PRECIOUS NATURAL POLIRANO	013
08 PRECIOUS NATURAL SATIN	013
09 DREAMBLUE WHITE POLIRANA	015
10 DREAMBLUE WHITE SATIN	015
11 SLABS PERLA POLIRANA	017
12 SLABS PERLA SATIN	017
13 KALAHARI BLACK POLIRANA	019
14 KALAHARI BLACK SATIN	019
15 ICELAND WHITE POLIRANA	021
16 ICELAND TOPAZ POLIRANA	023
17 ICELAND MINT POLIRANA	025
18 ICELAND NAVY POLIRANA	027
19 ICELAND MIDNIGHT POLIRANA	029
20 ZEBRANO NATURAL POLIRANA	031
21 CHRISTY WHITE POLIRANA	033
22 CHRISTY BONE POLIRANA	035
23 LENNON OCRE	037
24 ESTORM POLIRANA	039
25 INFINITY BLANCO POLIRANA	041
26 INFINITY NEGRO POLIRANO	041
27 LINGTON PERLA MAT	043
28 LINGTON CREMA MAT	045
29 BALTIMOR GRIS MAT	047
30 ZANZIBAR BEIGE MAT	049
31 POLIN ALUMINIO MAT	051
32 POLIN CORTEN MAT	053
33 POLIN FERRO MAT	055
34 MYLOS BONE MAT	057
35 MYLOS GREY MAT	059
36 TABIL NATURAL MAT	061
37 ZIRO PERLA MAT	063
38 ZIRO BEIGE MAT	065

# GRANDE

## 120X260

39 BELLADONNA BEIGE POLIRANA	069
40 BELLADONNA CHIARO POLIRANA	071
41 BELLADONNA FUMO POLIRANA	073
42 MANHATTAN EARTH POLIRANA	075
43 MANHATTAN EARTH SATIN	077
44 MANHATTAN OCEAN POLIRANA	077
45 MANHATTAN OCEAN SATIN	079
46 MANHATTAN MIDNIGHT POLIRANA	079
47 MANHATTAN DARK SATIN	081
48 REEF PULIDO	081
49 ULURU POLIRANA	083
50 RIALTO AVORIO POLIRANA	085
51 RIALTO CENERE POLIRANA	087
52 THOLOS WHITE POLIRANA	089
53 THOLOS WHITE MAT	089
54 MURANO POLIRANA	091
55 STORM WHITE MAT	093
56 STORM CLOUD MAT	095
57 STORM GREY MAT	097
58 STORM CREAM MAT	099
59 STORM EARTH MAT	101
60 MOHER NUT MAT	103
61 MOHER ASH MAT	105
62 MOHER ALBAR MAT	107
PREPORUKE ZA UGRADNJU	108
TEHNIČKI PODACI	116

120X280





120 x 280  
Shira Black polirana

# 01

## Shira Black

polirana



# 02

## Shira Black

satin

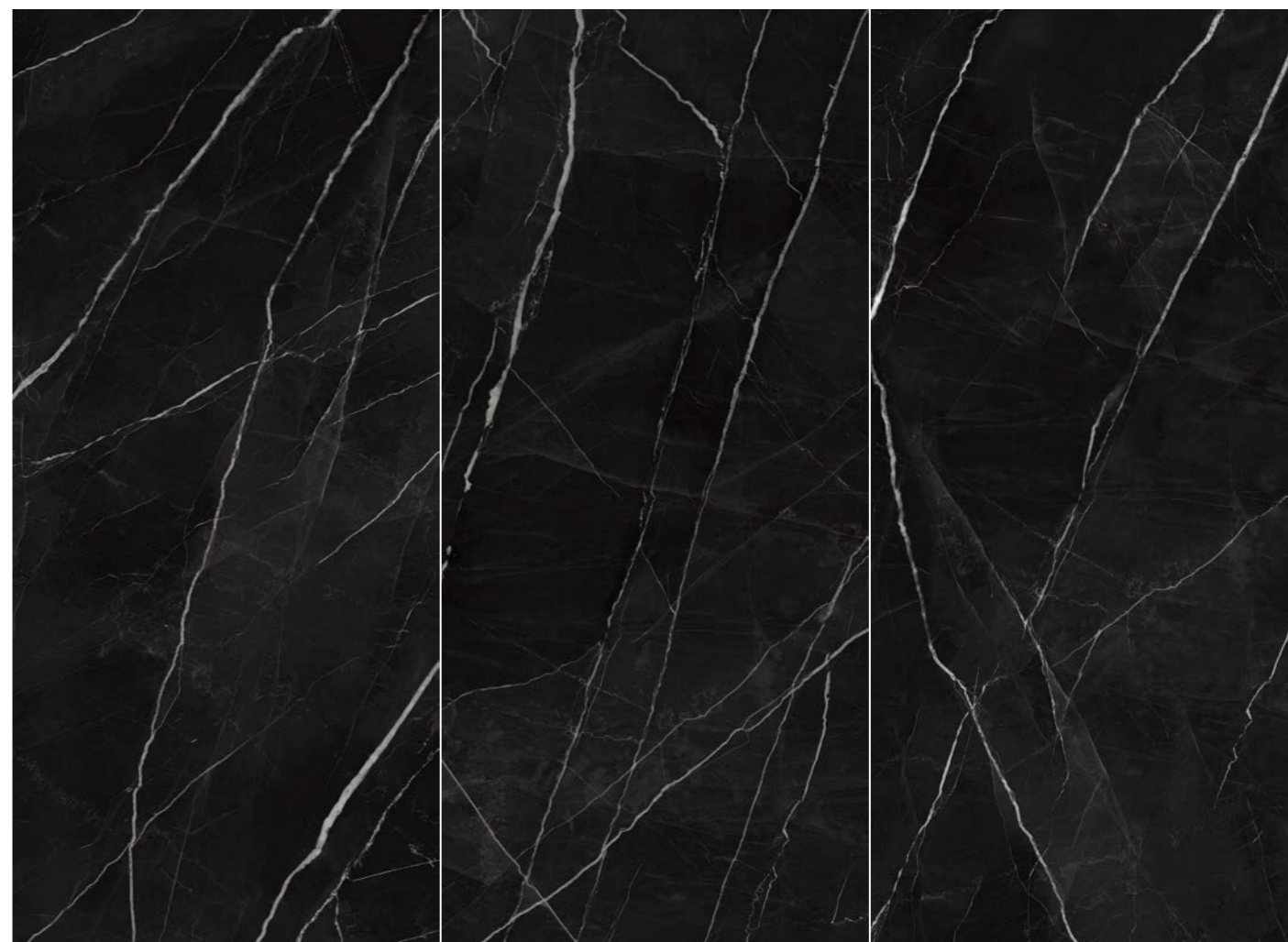

Dostupni formati:

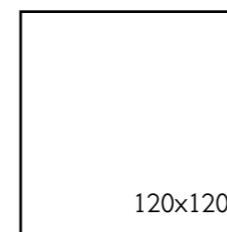
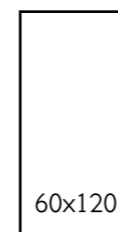

	Kod	Format (cm)	Debljina (mm)	Površina	Pločica u kutiji	m <sup>2</sup> po kutiji	Kg po kutiji	Kutija na paleti	m <sup>2</sup> na paleti	Kg na paleti
 Made in SPAIN	M230	120x280	6	Polirna	1	3.36	52	20	67.20	1040
	M220	120x280	6	Satin	1	3.36	52	20	67.20	1040





120 x 280  
Marhall White satin

# 03

## Marshall White

polirana



# 04

## Marshall White

satin



Dostupni formati:

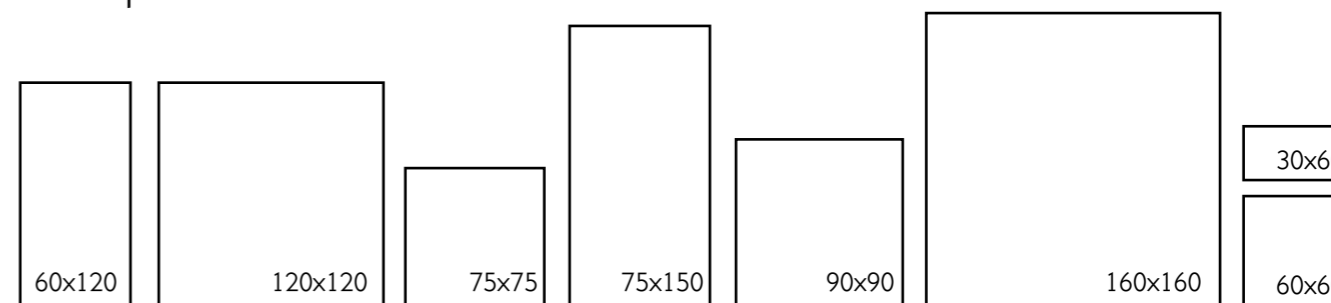

Kod	Format (cm)	Debljina (mm)	Površina	Pločica u kutiji	m <sup>2</sup> po kutiji	Kg po kutiji	Kutija na paleti	m <sup>2</sup> na paleti	Kg na paleti
M230	120x280	6	Polirna	1	3.36	52	20	67.20	1040
M220	120x280	6	Satin	1	3.36	52	20	67.20	1040







# 05

## Marshall Gold

polirana



# 06

## Marshall Gold

satin



Dostupni formati:

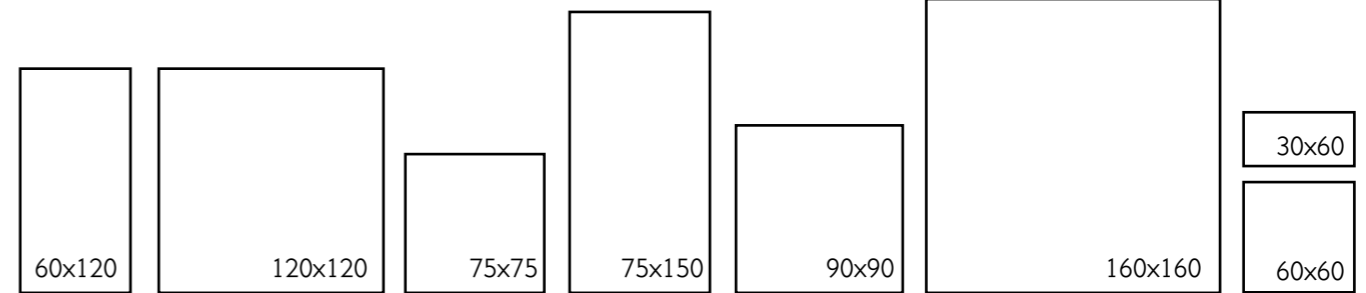

120 x 280  
Marhall Gold polirana

Kod	Format (cm)	Debljina (mm)	Površina	Pločica u kutiji	m <sup>2</sup> po kutiji	Kg po kutiji	Kutija na paleti	m <sup>2</sup> na paleti	Kg na paleti
M230	120x280	6	Polirna	1	3.36	52	20	67.20	1040
M220	120x280	6	Satin	1	3.36	52	20	67.20	1040







120 x 280  
Precious Natural polirana

# 07

Precious Natural  
polirana



# 08

Precious Natural  
satin



Dostupni formati:

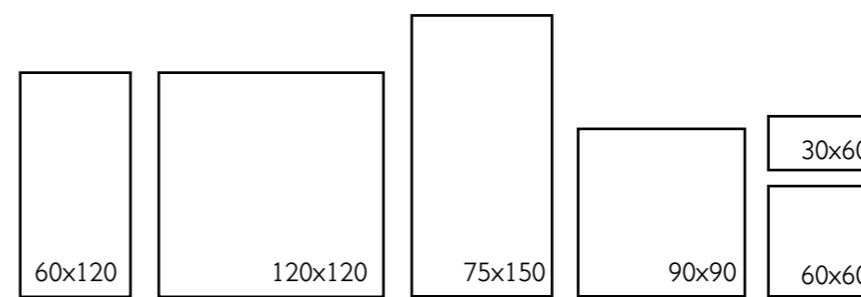

Kod	Format (cm)	Debljina (mm)	Površina	Pločica u kutiji	m <sup>2</sup> po kutiji	Kg po kutiji	Kutija na paleti	m <sup>2</sup> na paleti	Kg na paleti
M230	120x280	6	Polirna	1	3.36	52	20	67.20	1040
M220	120x280	6	Satin	1	3.36	52	20	67.20	1040







120 x 280  
Dreamblue White satin

# 09

## Dreamblue White

polirana



# 10

## Dreamblue White

satin



Dostupni formati:

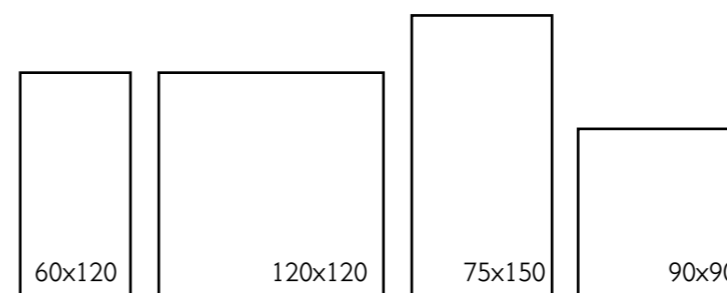

	Kod	Format (cm)	Debljina (mm)	Površina	Pločica u kutiji	m <sup>2</sup> po kutiji	Kg po kutiji	Kutija na paleti	m <sup>2</sup> na paleti	Kg na paleti
 Made in SPAIN	M230	120x280	6	Polirna	1	3.36	52	20	67.20	1040
	M220	120x280	6	Satin	1	3.36	52	20	67.20	1040





120 x 280  
Slabs Perla satin

# 11

## Slabs Perla polirana



# 12

## Slabs Perla satin

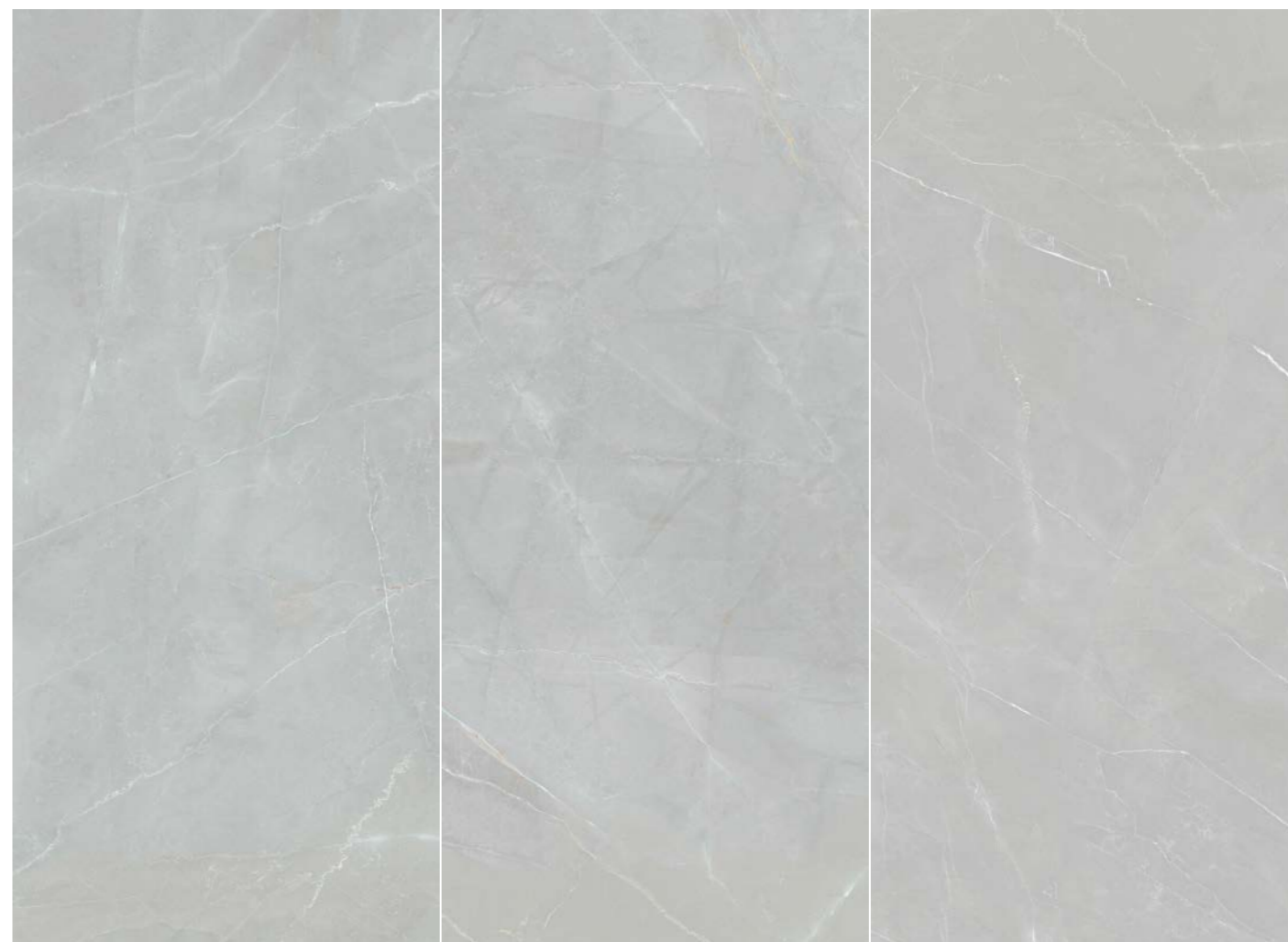

Dostupni formati:

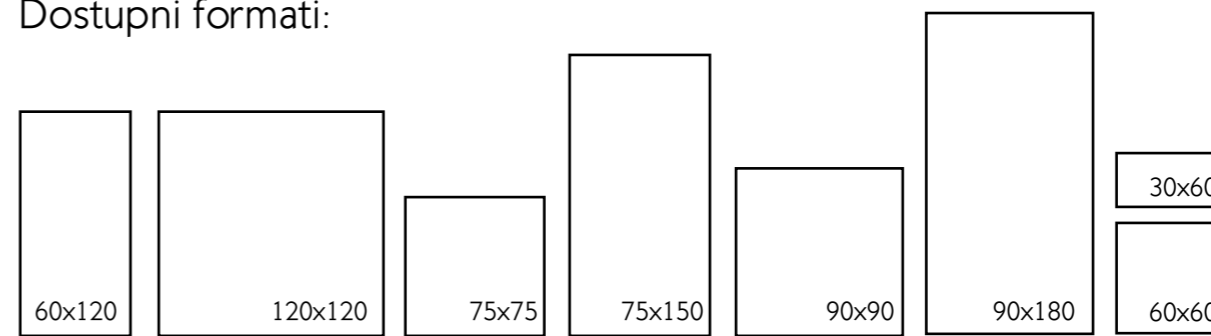

Kod	Format (cm)	Debljina (mm)	Površina	Pločica u kutiji	m <sup>2</sup> po kutiji	Kg po kutiji	Kutija na paleti	m <sup>2</sup> na paleti	Kg na paleti
M230	120x280	6	Polirna	1	3.36	52	20	67.20	1040
M220	120x280	6	Satin	1	3.36	52	20	67.20	1040







120 x 280  
Kalahari Black polirana

# 13

## Kalahari Black

polirana



# 14

## Kalahari Black

satin

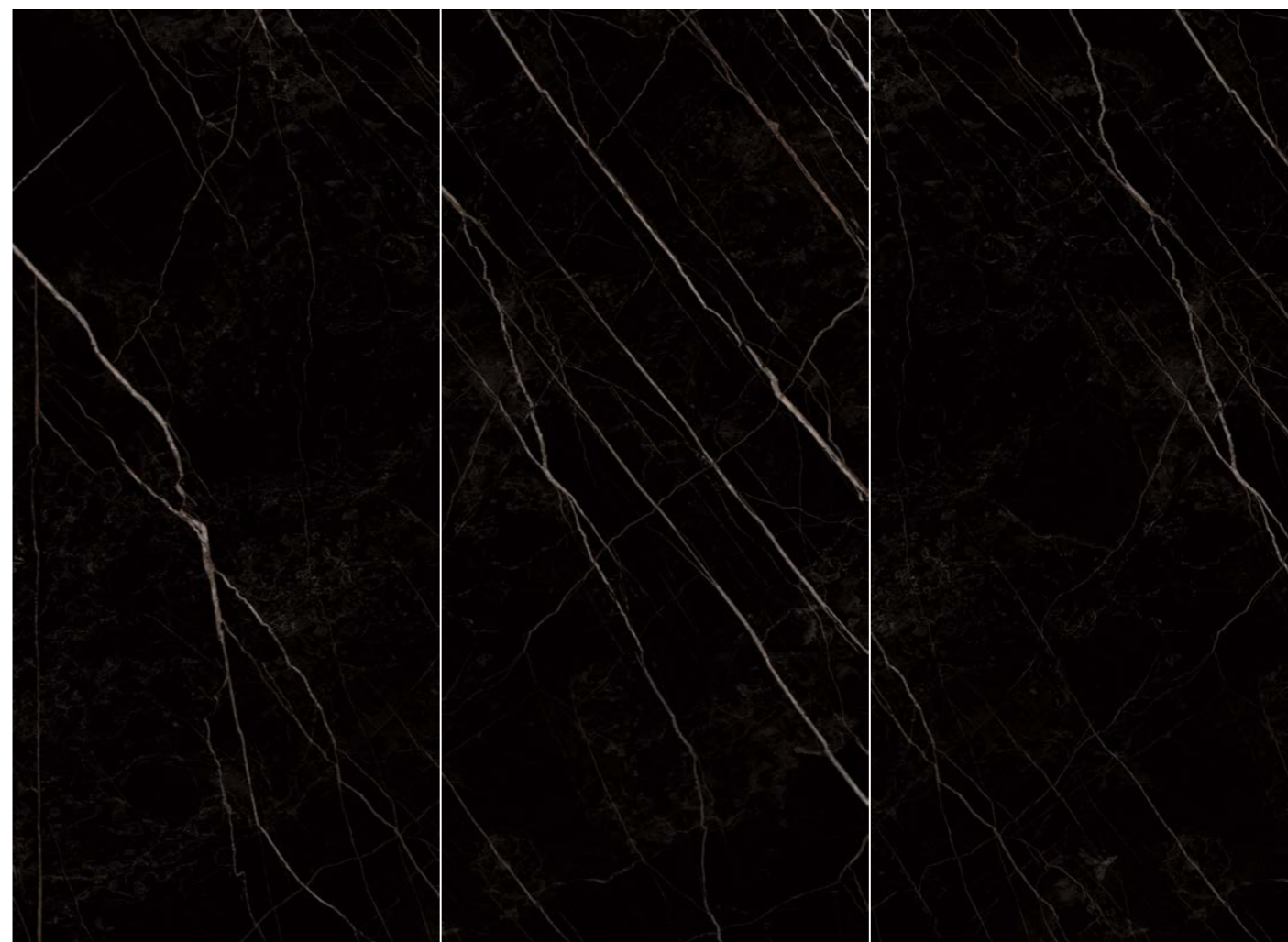

Dostupni formati:

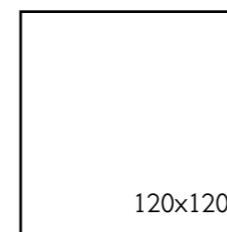
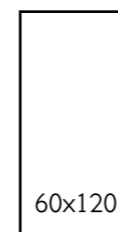

	Kod	Format (cm)	Debljina (mm)	Površina	Pločica u kutiji	m <sup>2</sup> po kutiji	Kg po kutiji	Kutija na paleti	m <sup>2</sup> na paleti	Kg na paleti
 Made in SPAIN	M230	120x280	6	Polirna	1	3.36	52	20	67.20	1040
	M220	120x280	6	Satin	1	3.36	52	20	67.20	1040





120 x 280  
Iceland White polirana

# 15

## Iceland White

polirana



Dostupni formati:

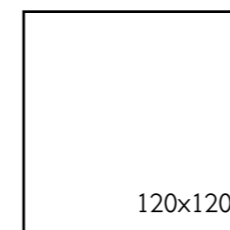
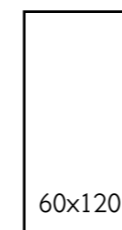

 Made in SPAIN	Kod	Format (cm)	Debljina (mm)	Površina	Pločica u kutiji	m <sup>2</sup> po kutiji	Kg po kutiji	Kutija na paleti	m <sup>2</sup> na paleti	Kg na paleti
	M230	120x280	6	Polirna	1	3.36	52	20	67.20	1040





120 x 280  
Iceland Topaz polirana

# 16

## Iceland Topaz polirana



Dostupni formati:

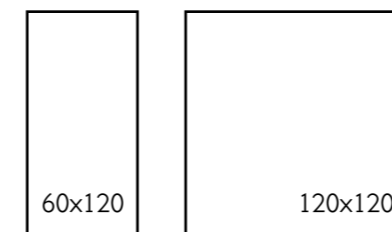

 Made in SPAIN	Kod	Format (cm)	Debljina (mm)	Površina	Pločica u kutiji	m <sup>2</sup> po kutiji	Kg po kutiji	Kutija na paleti	m <sup>2</sup> na paleti	Kg na paleti
	M230	120x280	6	Polirna	1	3.36	52	20	67.20	1040





120 x 280  
Iceland Mint polirana

# 17

## Iceland Mint

polirana

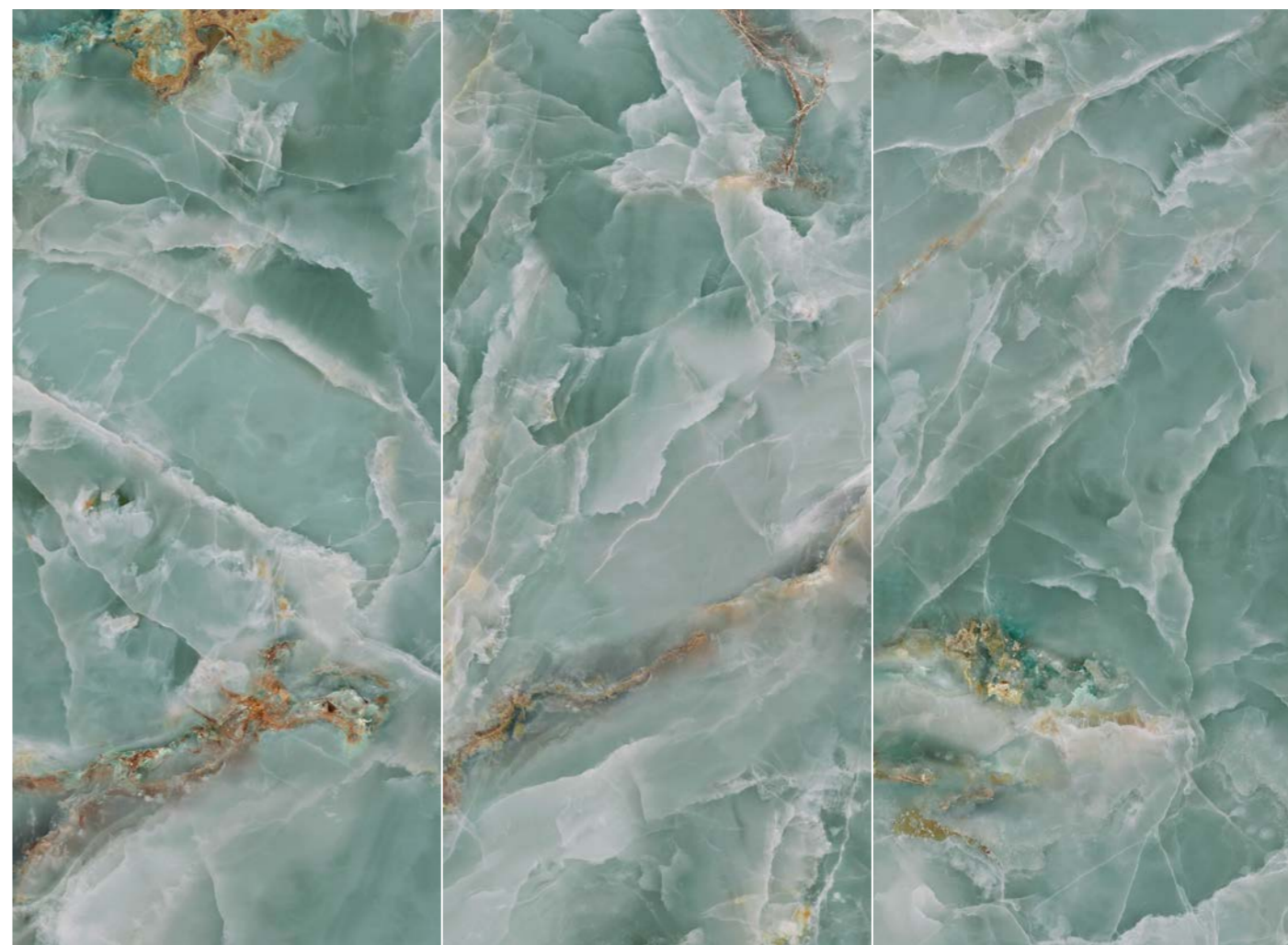

Dostupni formati:

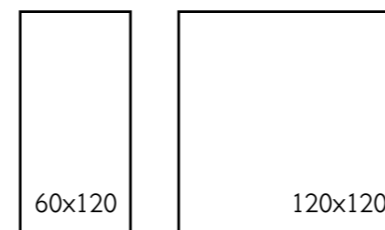

 Made in SPAIN	Kod	Format (cm)	Debljina (mm)	Površina	Pločica u kutiji	m <sup>2</sup> po kutiji	Kg po kutiji	Kutija na paleti	m <sup>2</sup> na paleti	Kg na paleti
	M230	120x280	6	Polirna	1	3.36	52	20	67.20	1040





120 x 280  
Iceland Navy polirana

# 18

## Iceland Navy

polirana

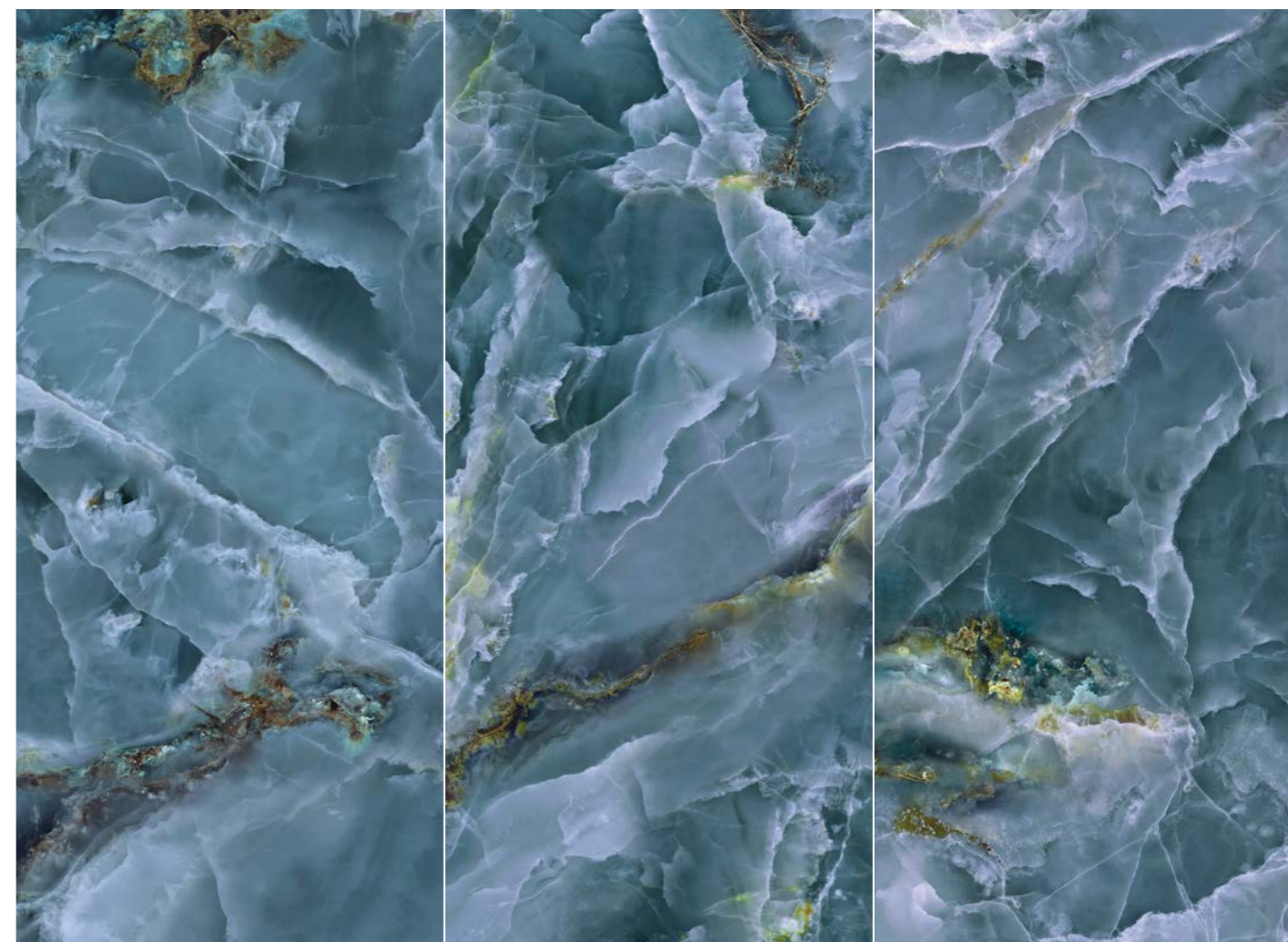

Dostupni formati:

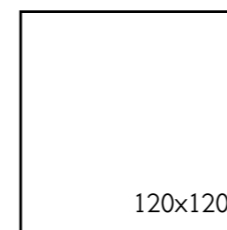
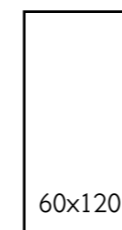

60x120

120x120

 Made in SPAIN	Kod	Format (cm)	Debljina (mm)	Površina	Pločica u kutiji	m <sup>2</sup> po kutiji	Kg po kutiji	Kutija na paleti	m <sup>2</sup> na paleti	Kg na paleti
	M230	120x280	6	Polirna	1	3.36	52	20	67.20	1040





120 x 280  
Iceland Midnight polirana

# 19

## Iceland Midnight polirana

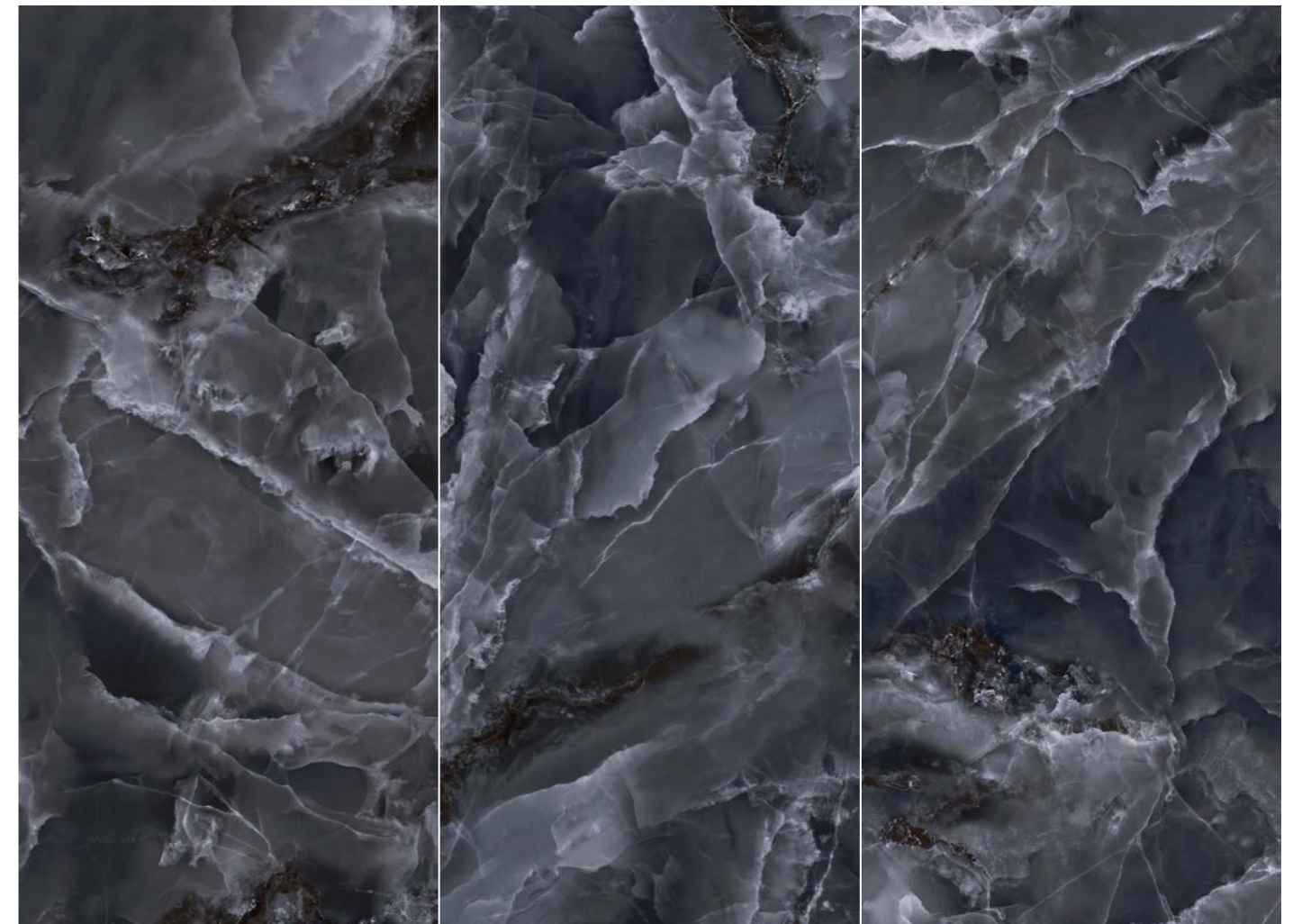

Dostupni formati:

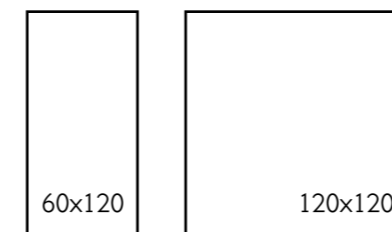

 Made in SPAIN	Kod	Format (cm)	Debljina (mm)	Površina	Pločica u kutiji	m <sup>2</sup> po kutiji	Kg po kutiji	Kutija na paleti	m <sup>2</sup> na paleti	Kg na paleti
	M230	120x280	6	Polirna	1	3.36	52	20	67.20	1040







120 x 280  
Zebrano Natural polirana

# 20

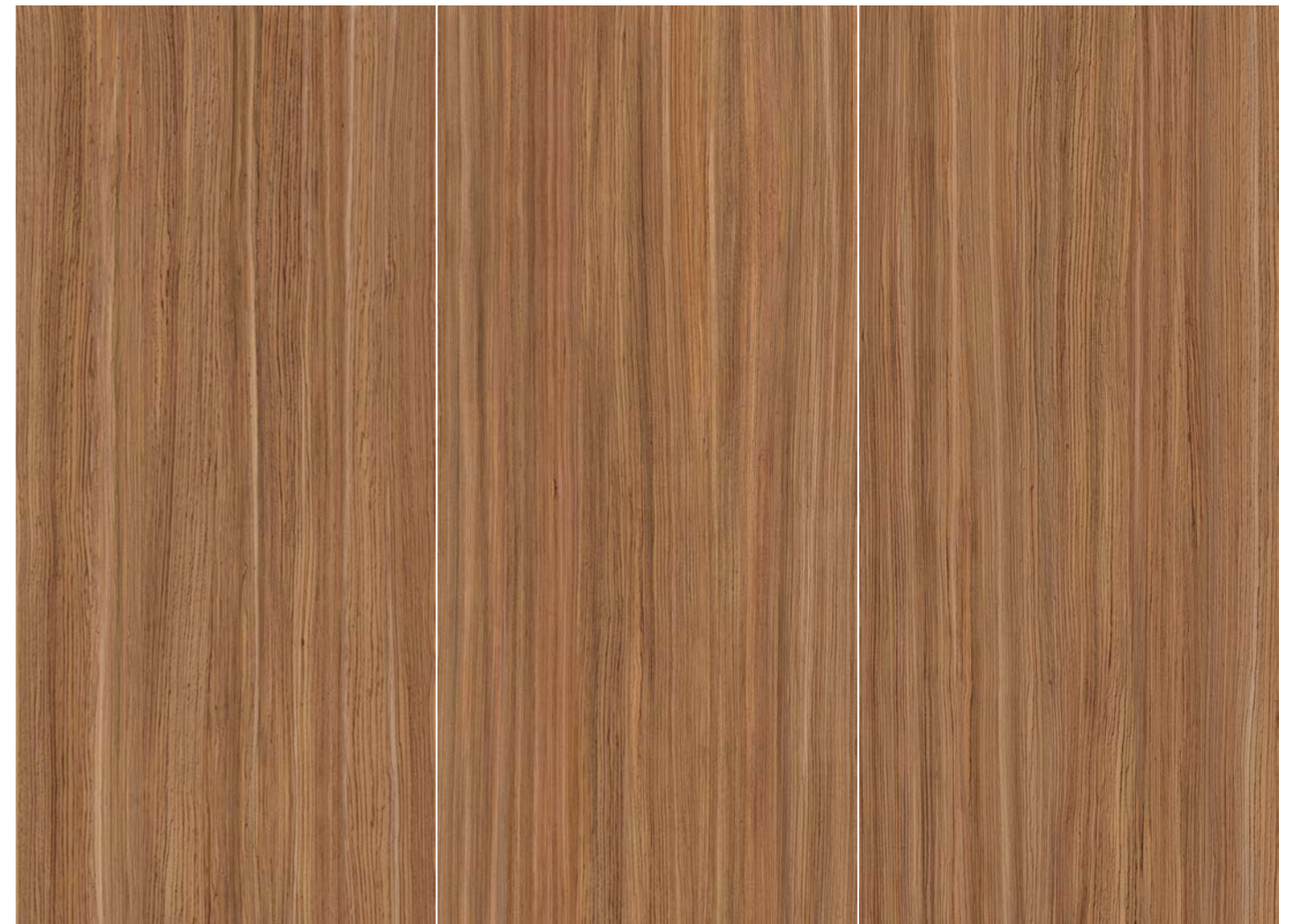
Zebrano Natural  
polirana



 Made in SPAIN	Kod	Format (cm)	Debljina (mm)	Površina	Pločica u kutiji	m <sup>2</sup> po kutiji	Kg po kutiji	Kutija na paleti	m <sup>2</sup> na paleti	Kg na paleti
	M230	120x280	6	Polirna	1	3.36	52	20	67.20	1062





# 21

Christy White  
polirana



120 x 280  
Christy White polirana

 Made in SPAIN	Kod	Format (cm)	Debljina (mm)	Površina	Pločica u kutiji	m <sup>2</sup> po kutiji	Kg po kutiji	Kutija na paleti	m <sup>2</sup> na paleti	Kg na paleti
	M230	120x280	6	Polirna	1	3.36	52	20	67.20	1062





# 22

## Christy Bone

polirana



120 x 280  
Christy Bone polirana

 Made in SPAIN	Kod	Format (cm)	Debljina (mm)	Površina	Pločica u kutiji	m <sup>2</sup> po kutiji	Kg po kutiji	Kutija na paleti	m <sup>2</sup> na paleti	Kg na paleti
	M230	120x280	6	Polirna	1	3.36	52	20	67.20	1062





# 23

## Lennon Ocre polirana



120 x 280  
Lennon Ocre polirana

 Made in SPAIN	Kod	Format (cm)	Debljina (mm)	Površina	Pločica u kutiji	m <sup>2</sup> po kutiji	Kg po kutiji	Kutija na paleti	m <sup>2</sup> na paleti	Kg na paleti
	M230	120x280	6	Polirna	1	3.36	52	20	67.20	1062





# 24

Estrom  
polirana



120 x 280  
Estrom polirana

 Made in SPAIN	Kod	Format (cm)	Debljina (mm)	Površina	Pločica u kutiji	m <sup>2</sup> po kutiji	Kg po kutiji	Kutija na paleti	m <sup>2</sup> na paleti	Kg na paleti
	M230	120x280	6	Polirna	1	3.36	52	20	67.20	1062





120 x 280  
 Infinity Blanco polirana  
 Infinity Negro polirana

# 25

Infinity Blanco  
 polirana

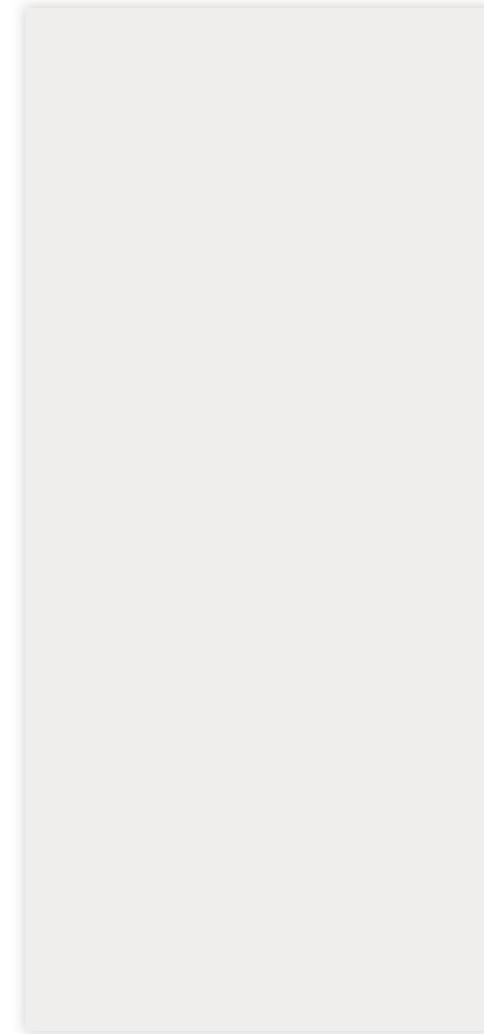

# 26

Infinity Negro  
 polirana



 Made in SPAIN	Kod	Format (cm)	Debljina (mm)	Površina	Pločica u kutiji	m <sup>2</sup> po kutiji	Kg po kutiji	Kutija na paleti	m <sup>2</sup> na paleti	Kg na paleti
	M230	120x280	6	Polirna	1	3.36	52	20	67.20	1062





120 x 280  
Lington Perla mat

# 27

## Lington Perla mat



Dostupni formati:

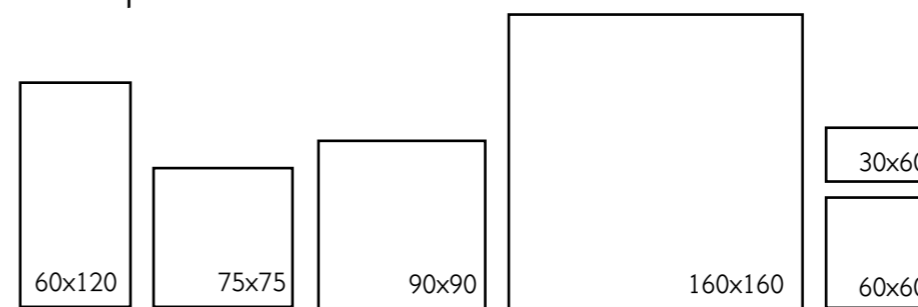

 Made in SPAIN	Kod	Format (cm)	Debljina (mm)	Površina	Pločica u kutiji	m <sup>2</sup> po kutiji	Kg po kutiji	Kutija na paleti	m <sup>2</sup> na paleti	Kg na paleti
	M220	120x280	6	Mat	1	3.36	52	20	67.20	1040





120 x 280  
Lington Crema mat

# 28

## Lington Crema mat



Dostupni formati:

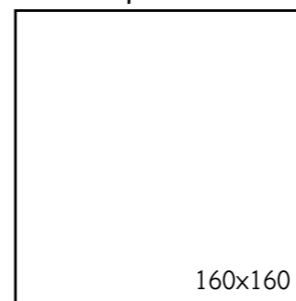

160x160

 Made in SPAIN	Kod	Format (cm)	Debljina (mm)	Površina	Pločica u kutiji	m <sup>2</sup> po kutiji	Kg po kutiji	Kutija na paleti	m <sup>2</sup> na paleti	Kg na paleti
	M220	120x280	6	Mat	1	3.36	52	20	67.20	1040





120 x 280  
Baltimot Gris mat

# 29

## Baltimore Gris

mat

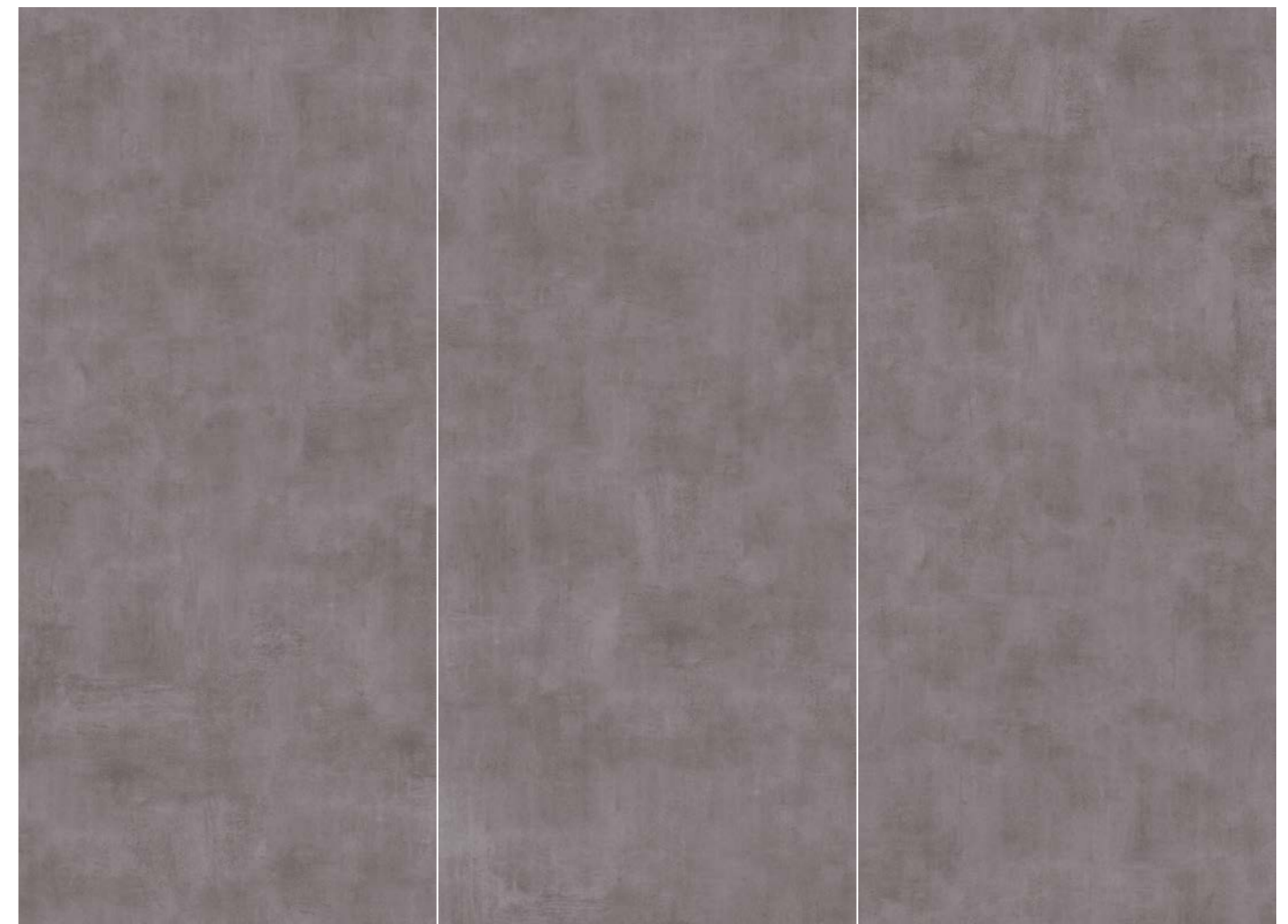

Dostupni formati:

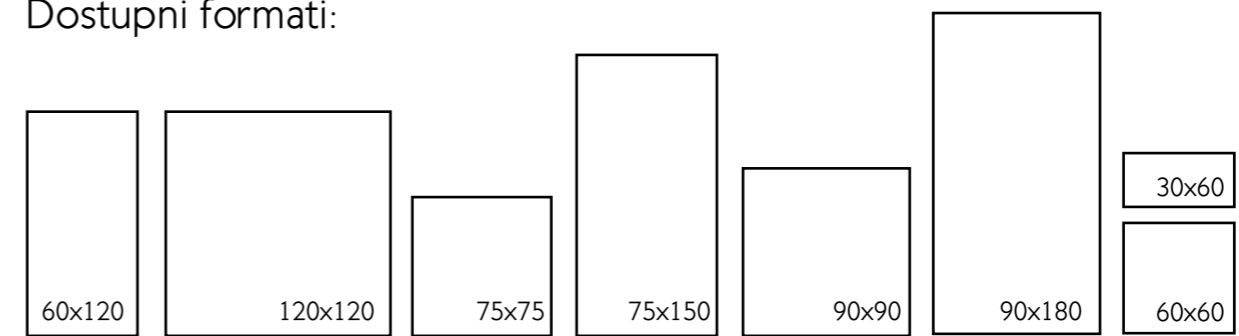

 Made in SPAIN	Kod	Format (cm)	Debljina (mm)	Površina	Pločica u kutiji	m <sup>2</sup> po kutiji	Kg po kutiji	Kutija na paleti	m <sup>2</sup> na paleti	Kg na paleti
	M220	120x280	6	Mat	1	3.36	52	20	67.20	1040





120 x 280  
Zanzibar Beige mat

# 30

## Zanzibar Beige

mat



Dostupni formati:



 Made in SPAIN	Kod	Format (cm)	Debljina (mm)	Površina	Pločica u kutiji	m <sup>2</sup> po kutiji	Kg po kutiji	Kutija na paleti	m <sup>2</sup> na paleti	Kg na paleti
	M220	120x280	6	Mat	1	3.36	52	20	67.20	1040





120 x 280  
Polin Aluminio mat

# 31

## Polin Aluminio

mat



 Made in SPAIN	Kod	Format (cm)	Debljina (mm)	Površina	Pločica u kutiji	m <sup>2</sup> po kutiji	Kg po kutiji	Kutija na paleti	m <sup>2</sup> na paleti	Kg na paleti
	M220	120x280	6	Mat	1	3.36	52	20	67.20	1040





# 32

## Polin Corten

mat



120 x 280  
Polin Corten mat

 Made in SPAIN	Kod	Format (cm)	Debljina (mm)	Površina	Pločica u kutiji	m <sup>2</sup> po kutiji	Kg po kutiji	Kutija na paleti	m <sup>2</sup> na paleti	Kg na paleti
	M220	120x280	6	Mat	1	3.36	52	20	67.20	1040





120 x 280  
Polin Ferro mat

# 33

## Polin Ferro mat



 Made in SPAIN	Kod	Format (cm)	Debljina (mm)	Površina	Pločica u kutiji	m <sup>2</sup> po kutiji	Kg po kutiji	Kutija na paleti	m <sup>2</sup> na paleti	Kg na paleti
	M220	120x280	6	Mat	1	3.36	52	20	67.20	1040





120 x 280  
Mylos Bone mat

# 34

## Mylos Bone mat

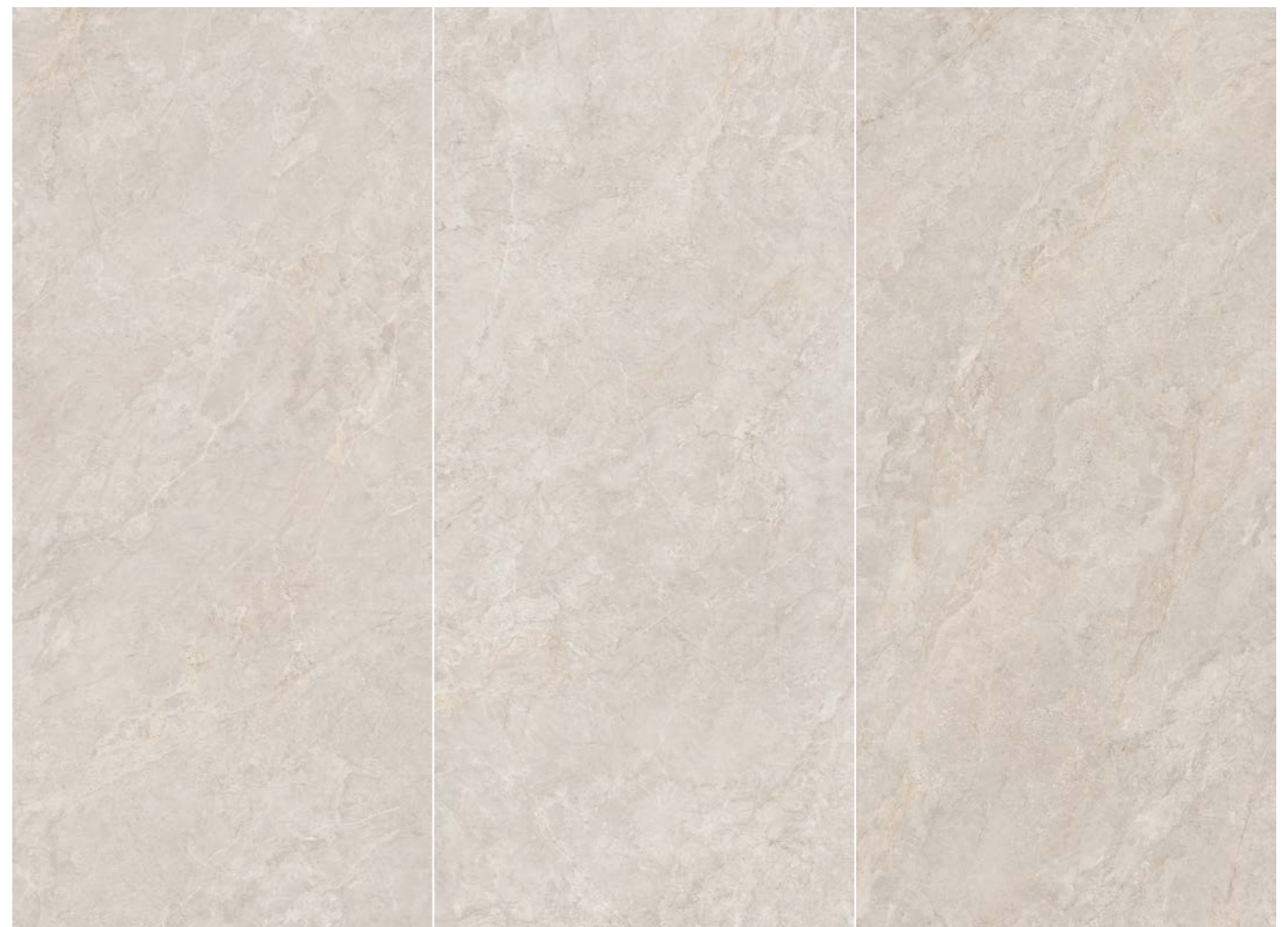

Dostupni formati:

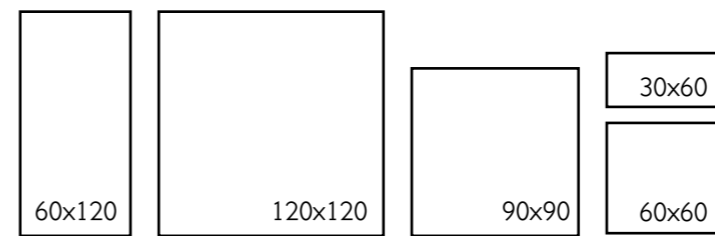

 Made in SPAIN	Kod	Format (cm)	Debljina (mm)	Površina	Pločica u kutiji	m <sup>2</sup> po kutiji	Kg po kutiji	Kutija na paleti	m <sup>2</sup> na paleti	Kg na paleti
	M220	120x280	6	Mat	1	3.36	52	20	67.20	1040





120 x 280  
Mylos Grey mat

# 35

## Mylos Grey

mat

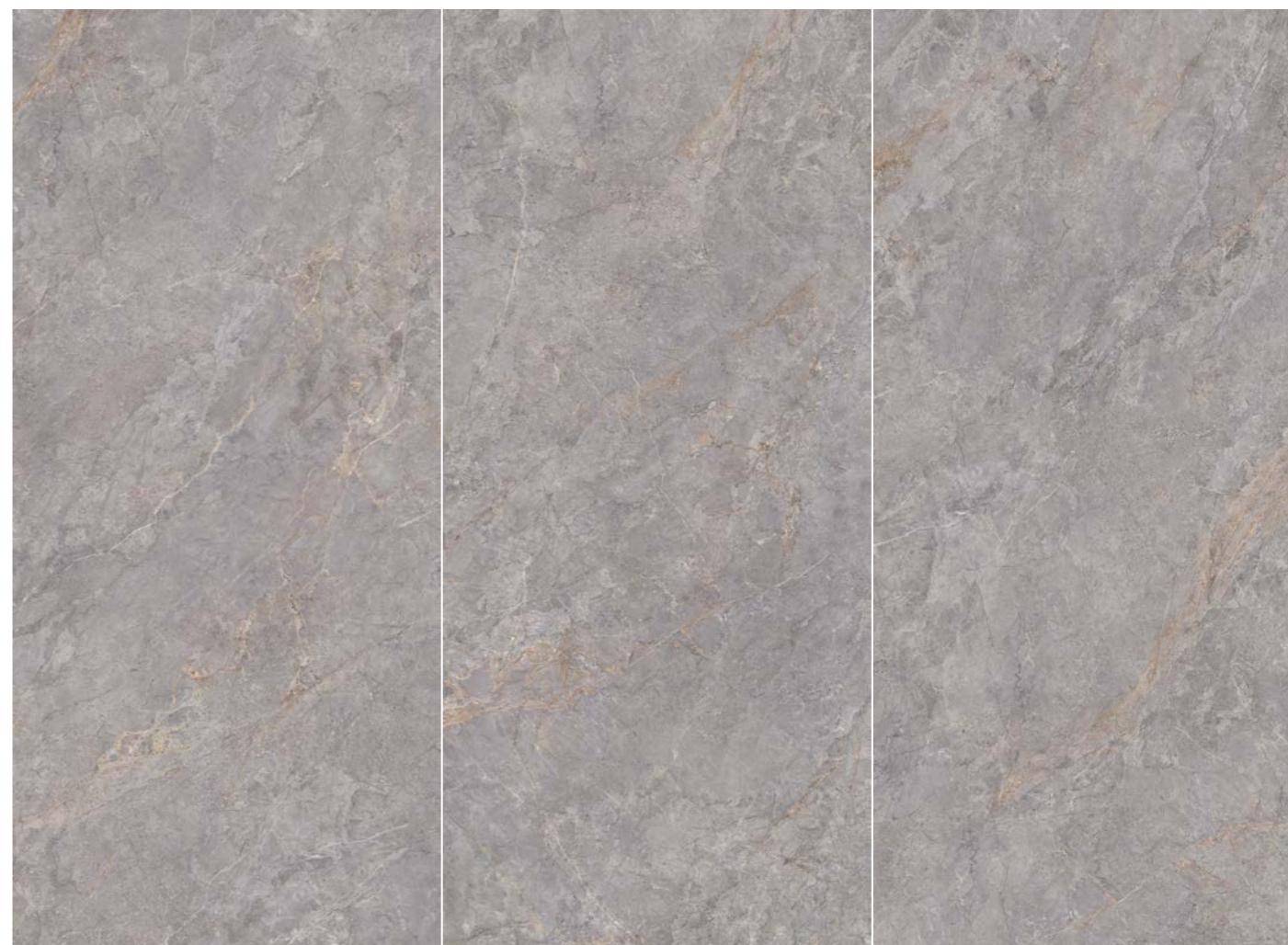

Dostupni formati:

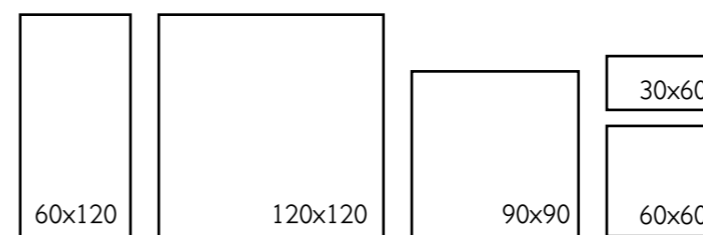

 Made in SPAIN	Kod	Format (cm)	Debljina (mm)	Površina	Pločica u kutiji	m <sup>2</sup> po kutiji	Kg po kutiji	Kutija na paleti	m <sup>2</sup> na paleti	Kg na paleti
	M220	120x280	6	Mat	1	3.36	52	20	67.20	1040







120 x 280  
Tabil Natural mat

# 36

## Tabil Natural

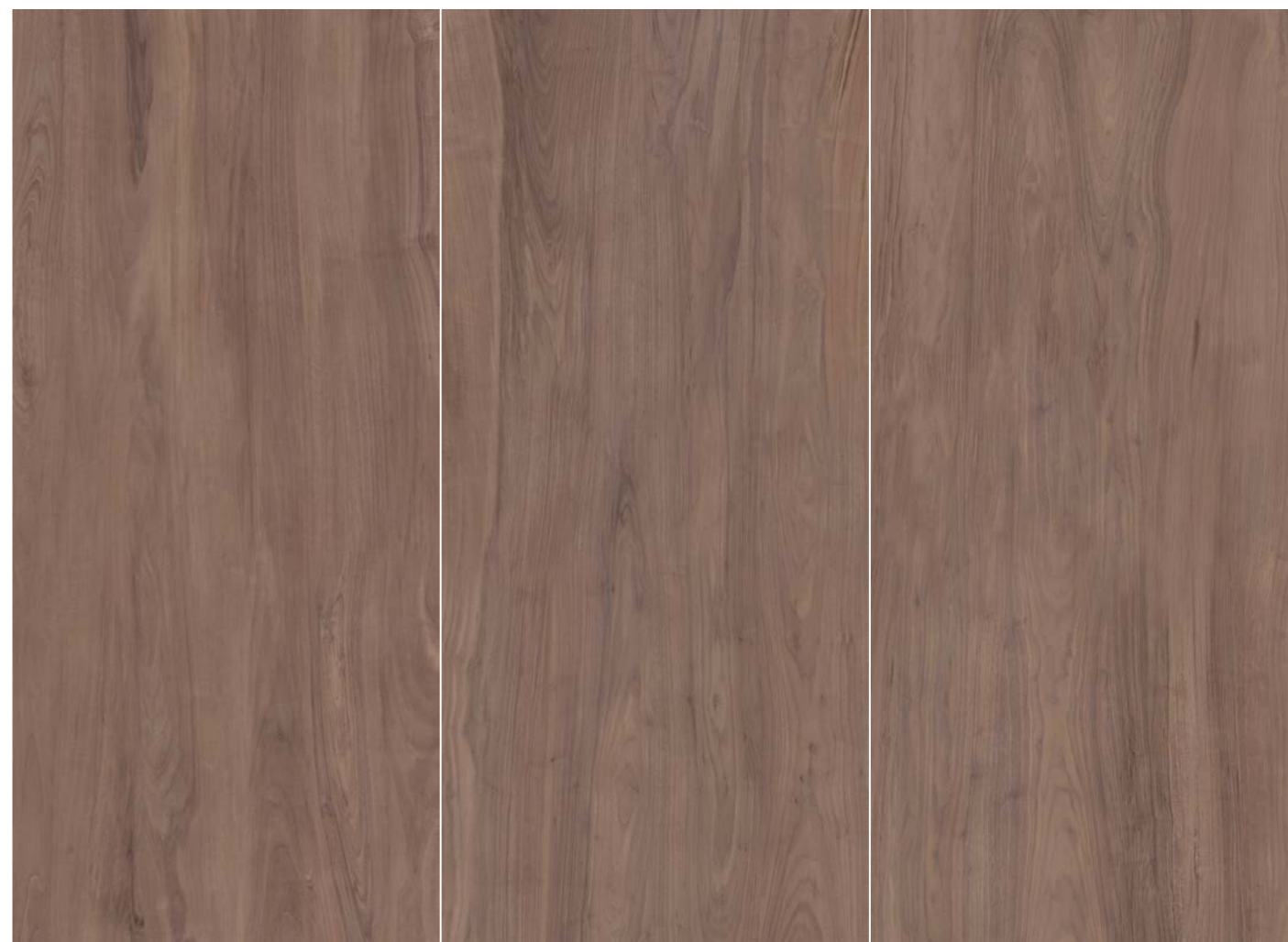
mat



 Made in SPAIN	Kod	Format (cm)	Debljina (mm)	Površina	Pločica u kutiji	m <sup>2</sup> po kutiji	Kg po kutiji	Kutija na paleti	m <sup>2</sup> na paleti	Kg na paleti
	M220	120x280	6	Mat	1	3.36	52	20	67.20	1040





120 x 280  
Ziro Perla mat

# 37

## Ziro Perla mat



 Made in SPAIN	Kod	Format (cm)	Debljina (mm)	Površina	Pločica u kutiji	m <sup>2</sup> po kutiji	Kg po kutiji	Kutija na paleti	m <sup>2</sup> na paleti	Kg na paleti
	M220	120x280	6	Mat	1	3.36	52	20	67.20	1040





120 x 280  
Ziro Beigel mat

# 38

Ziro Beige  
mat



 Made in SPAIN	Kod	Format (cm)	Debljina (mm)	Površina	Pločica u kutiji	m <sup>2</sup> po kutiji	Kg po kutiji	Kutija na paleti	m <sup>2</sup> na paleti	Kg na paleti
	M220	120x280	6	Mat	1	3.36	52	20	67.20	1040

120X260





120 x 260  
Belladonna Beige polirana

# 39

## Belladonna Beige

polirana



Dostupni formati:

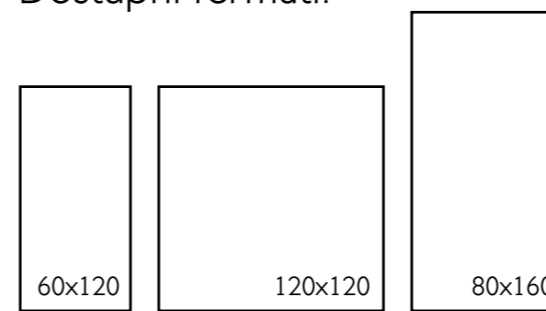

Kod	Format (cm)	Debljina (mm)	Površina	Pločica u kutiji	m <sup>2</sup> po kutiji	Kg po kutiji	Kutija na paleti	m <sup>2</sup> na paleti	Kg na paleti
M230	120x260	7	Polirna	1	3.12	52	18	56.16	936







120 x 260  
Belladonna Chiaro polirana

# 40

## Belladonna Chiaro

polirana



Dostupni formati:

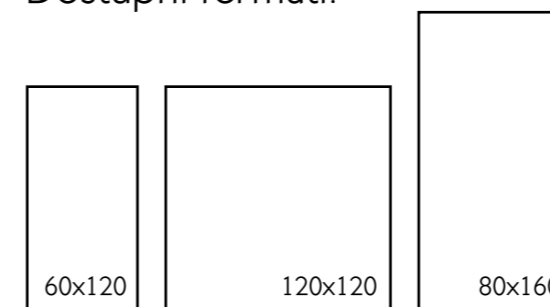

	Kod	Format (cm)	Debljina (mm)	Površina	Pločica u kutiji	m <sup>2</sup> po kutiji	Kg po kutiji	Kutija na paleti	m <sup>2</sup> na paleti	Kg na paleti
 Made in SPAIN	M230	120x260	7	Polirna	1	3.12	52	18	56.16	936





120 x 260  
Belladonna Fumo polirana

# 41

## Belladonna Fumo

polirana



Dostupni formati:

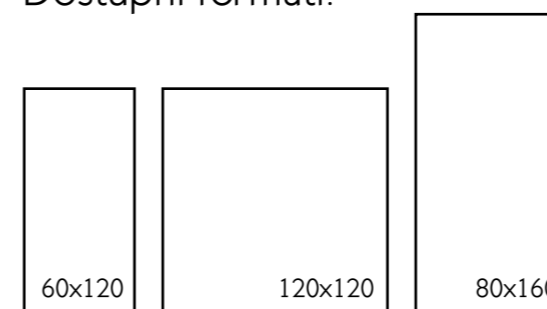

Kod	Format (cm)	Debljina (mm)	Površina	Pločica u kutiji	m <sup>2</sup> po kutiji	Kg po kutiji	Kutija na paleti	m <sup>2</sup> na paleti	Kg na paleti
M230	120x260	7	Polirna	1	3.12	52	18	56.16	936







120 x 260  
Manhattan Earth polirana

# 42

## Manhattan Earth

polirana



# 43

## Manhattan Earth

satin

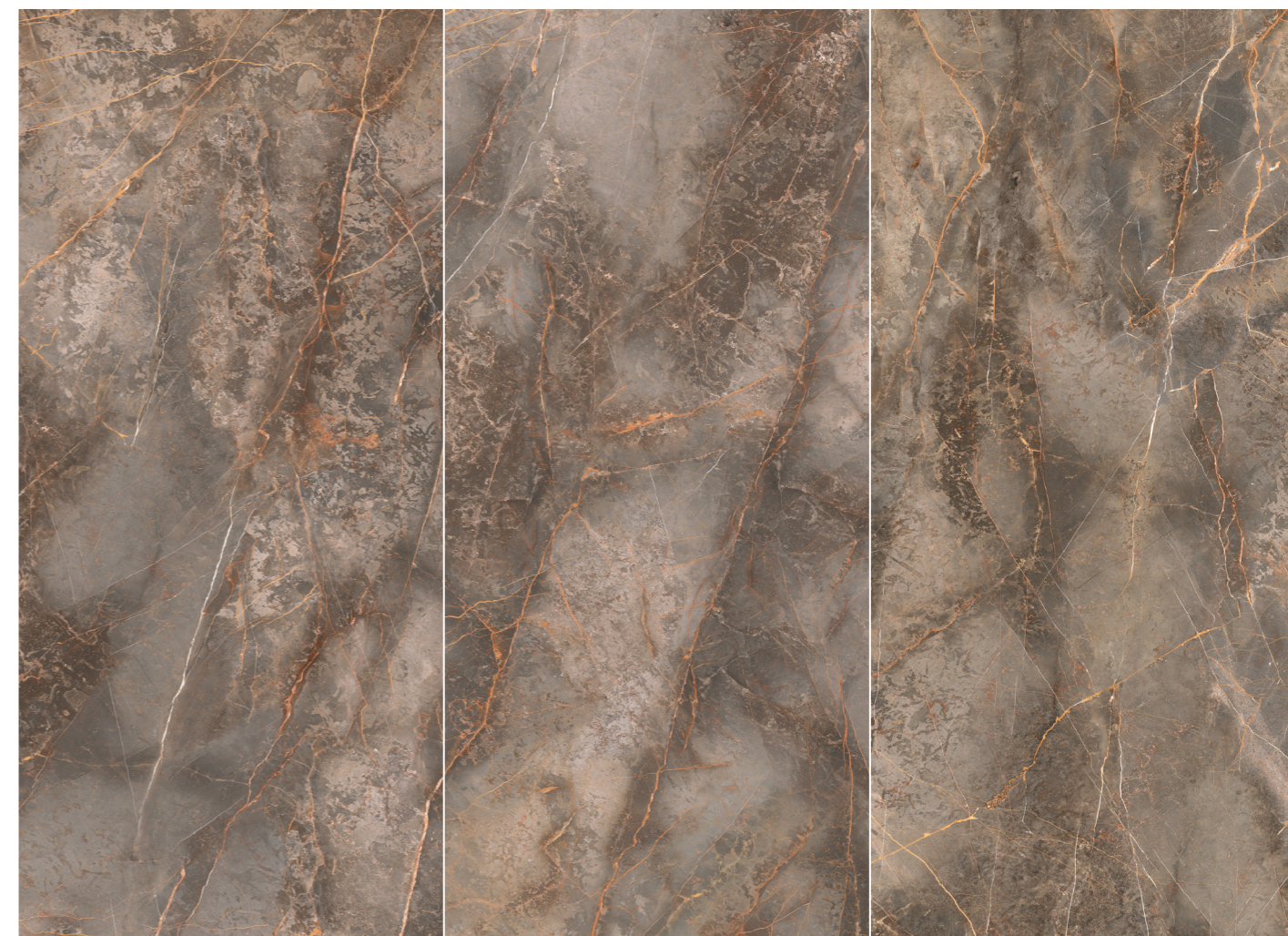

Dostupni formati:

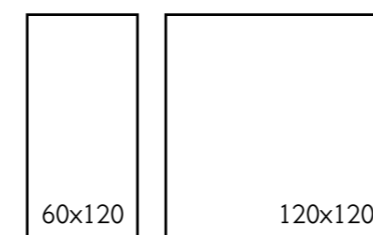

	Kod	Format (cm)	Debljina (mm)	Površina	Pločica u kutiji	m <sup>2</sup> po kutiji	Kg po kutiji	Kutija na paleti	m <sup>2</sup> na paleti	Kg na paleti
 Made in SPAIN	M230	120x260	7	Polirna	1	3.12	52	18	56.16	936
	M220	120x260	6	Mat	1	3.12	45.5	21	65.52	956





120 x 260  
Manhattan Ocean polirana

# 44

## Manhattan Ocean

polirana



# 45

## Manhattan Ocean

satin



Dostupni formati:

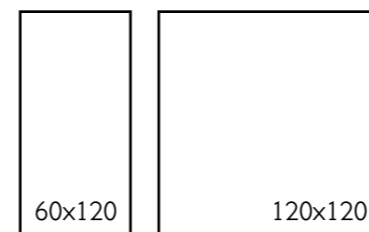

	Kod	Format (cm)	Debljina (mm)	Površina	Pločica u kutiji	m <sup>2</sup> po kutiji	Kg po kutiji	Kutija na paleti	m <sup>2</sup> na paleti	Kg na paleti
 Made in SPAIN	M230	120x260	7	Polirana	1	3.12	52	18	56.16	936
	M220	120x260	6	Mat	1	3.12	45.5	21	65.52	956





120 x 260  
Manhattan Dark polirana

# 46

Manhattan Midnight  
polirana



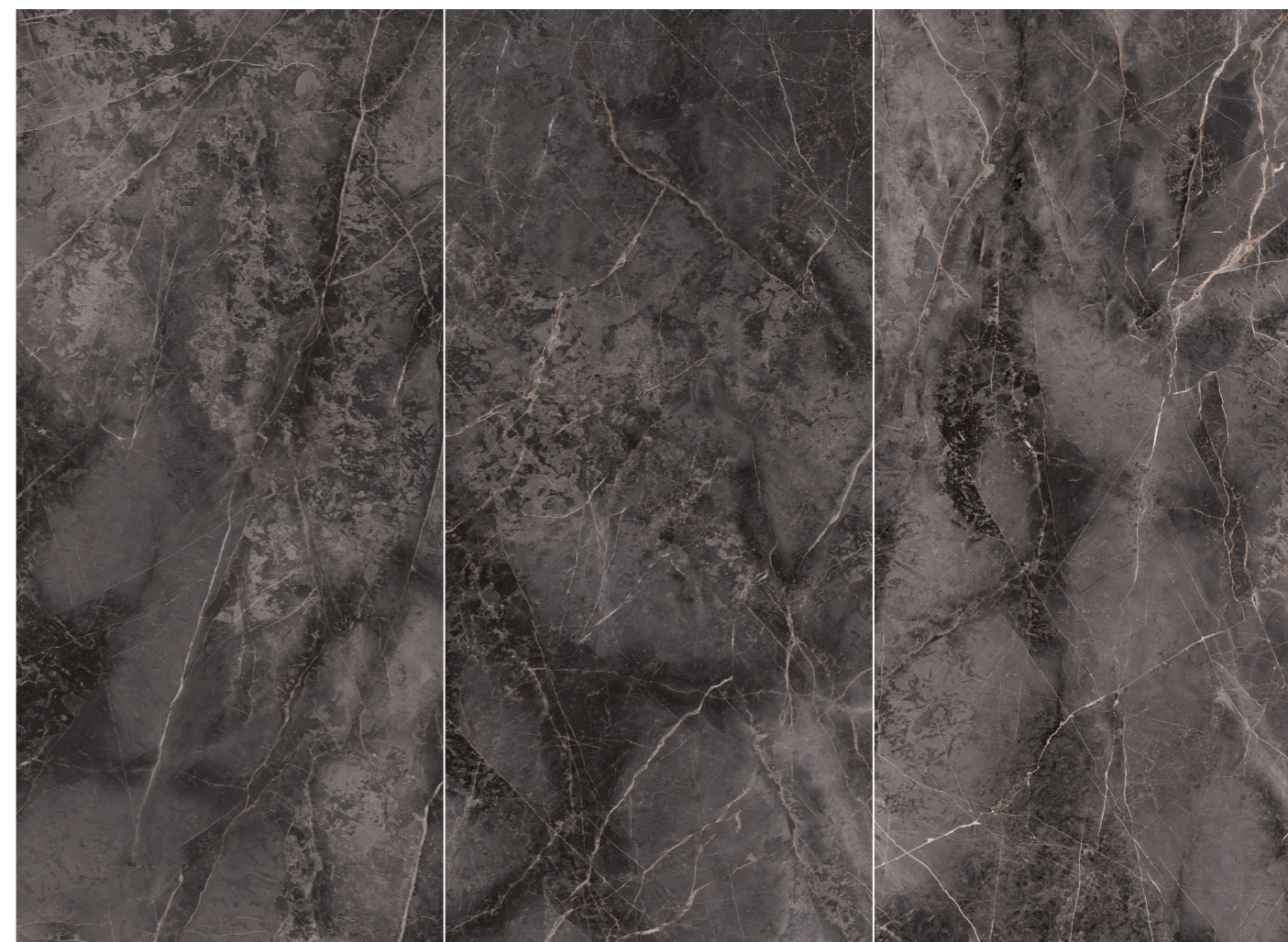

# 47

Manhattan Dark  
satin

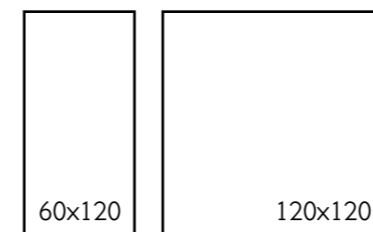

Dostupni formati:



	Kod	Format (cm)	Debljina (mm)	Površina	Pločica u kutiji	m <sup>2</sup> po kutiji	Kg po kutiji	Kutija na paleti	m <sup>2</sup> na paleti	Kg na paleti
 Made in SPAIN	M230	120x260	7	Polirna	1	3.12	52	18	56.16	936
	M220	120x260	6	Mat	1	3.12	45.5	21	65.52	956





120 x 260  
Reef polirana

# 48

## Reef Pulido

polirana

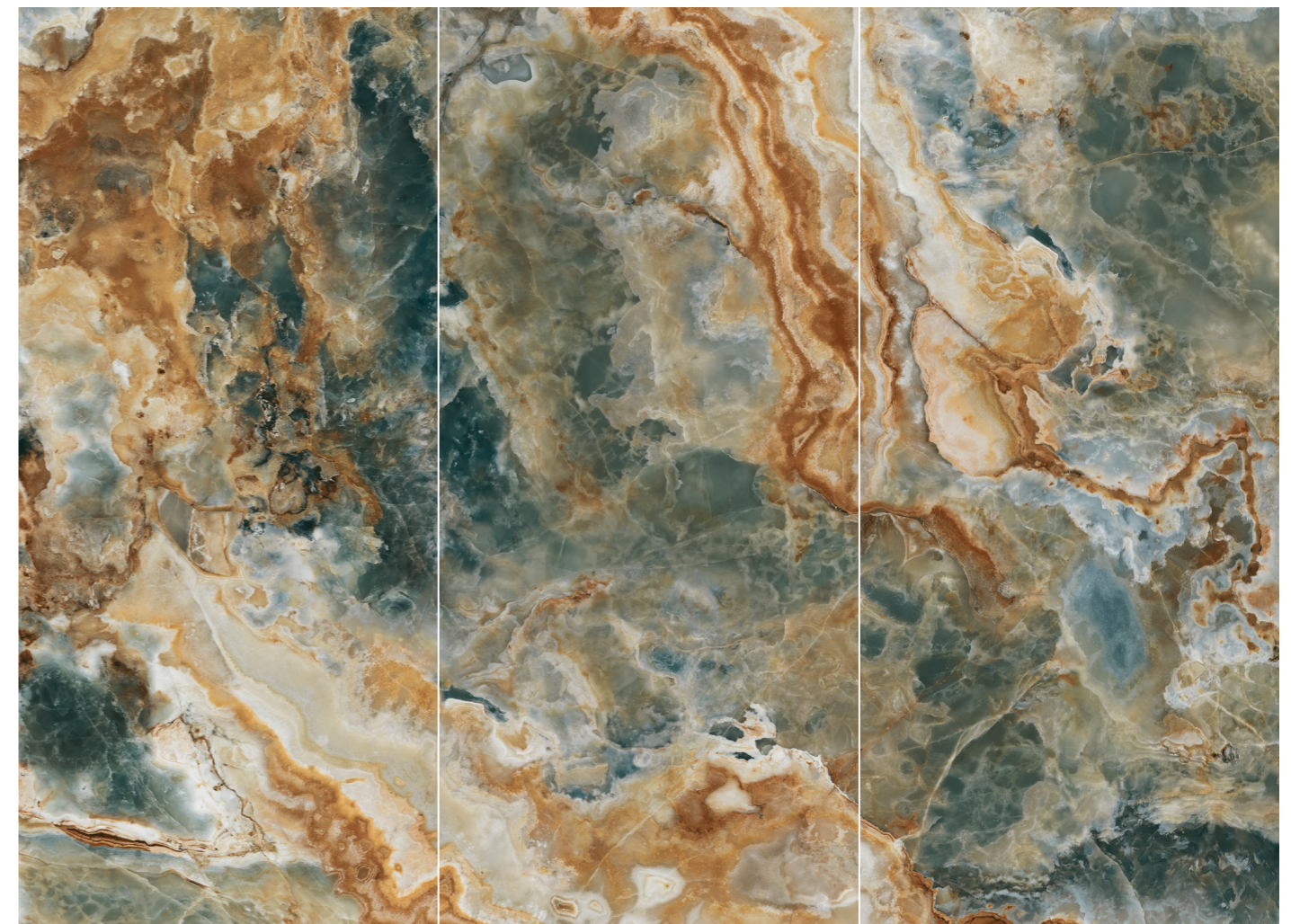

Dostupni formati:

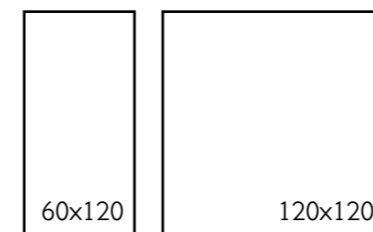

 Made in SPAIN	Kod	Format (cm)	Debljina (mm)	Površina	Pločica u kutiji	m <sup>2</sup> po kutiji	Kg po kutiji	Kutija na paleti	m <sup>2</sup> na paleti	Kg na paleti
	M230	120x260	7	Polirna	1	3.12	52	18	56.16	936





# 49

Uluru  
polirana



Dostupni formati:

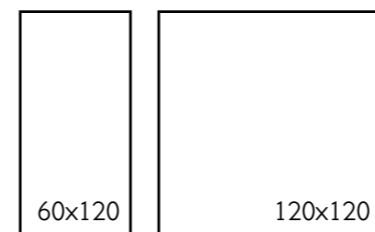

120 x 260  
Uluru polirana

 Made in SPAIN	Kod	Format (cm)	Debljina (mm)	Površina	Pločica u kutiji	m <sup>2</sup> po kutiji	Kg po kutiji	Kutija na paleti	m <sup>2</sup> na paleti	Kg na paleti
	M230	120x260	7	Polirna	1	3.12	52	18	56.16	936





# 50

## Rialto Avorio

polirana



Dostupni formati:

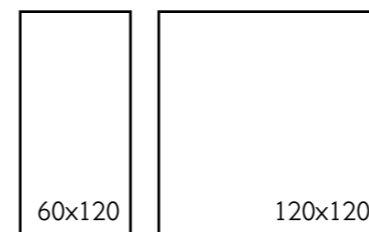

120 x 260  
Rialto Avorio polirana

 Made in SPAIN	Kod	Format (cm)	Debljina (mm)	Površina	Pločica u kutiji	m <sup>2</sup> po kutiji	Kg po kutiji	Kutija na paleti	m <sup>2</sup> na paleti	Kg na paleti
	M230	120x260	7	Polirna	1	3.12	52	18	56.16	936





120 x 260  
Rialto Cenere polirana

# 51

## Rialto Cenere

polirana



Dostupni formati:

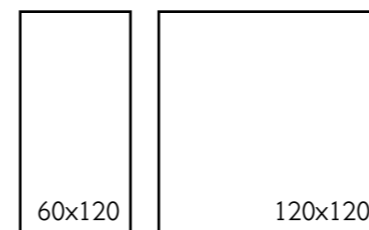

 Made in SPAIN	Kod	Format (cm)	Debljina (mm)	Površina	Pločica u kutiji	m <sup>2</sup> po kutiji	Kg po kutiji	Kutija na paleti	m <sup>2</sup> na paleti	Kg na paleti
	M230	120x260	7	Polirna	1	3.12	52	18	56.16	936





120 x 260  
Tholos White mat

# 52

## Tholos White

polirana



# 53

## Tholos White

mat

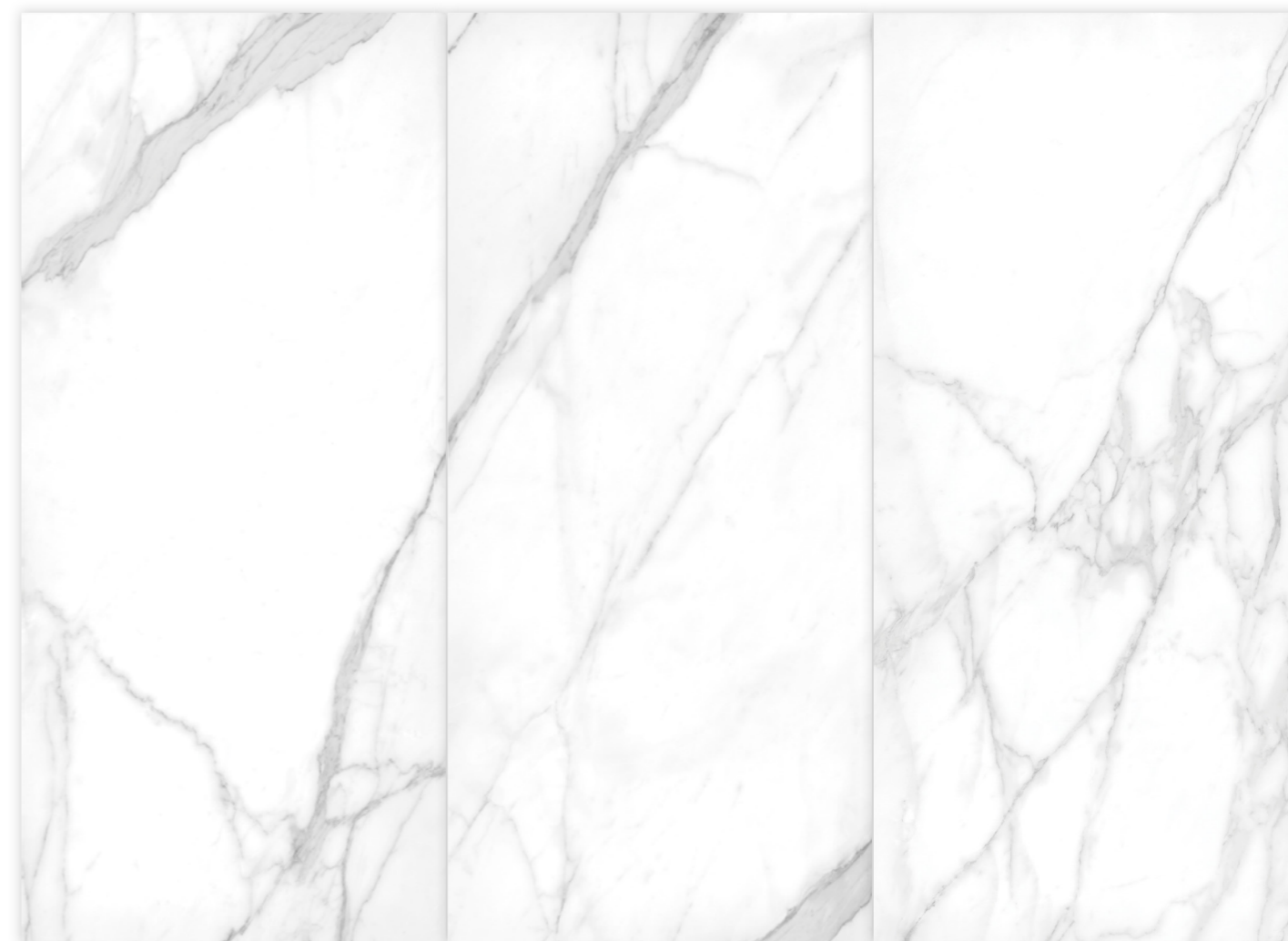

Dostupni formati:

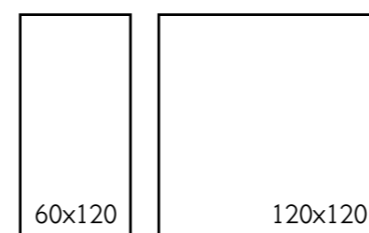

	Kod	Format (cm)	Debljina (mm)	Površina	Pločica u kutiji	m <sup>2</sup> po kutiji	Kg po kutiji	Kutija na paleti	m <sup>2</sup> na paleti	Kg na paleti
 Made in SPAIN	M230	120x260	6	Polirna	1	3.12	43.6	20	62.40	972
	M220	120x260	6	Mat	1	3.12	43.6	24	78.88	1.171





120 x 260  
Murano polirana

# 54

## Murano

polirana

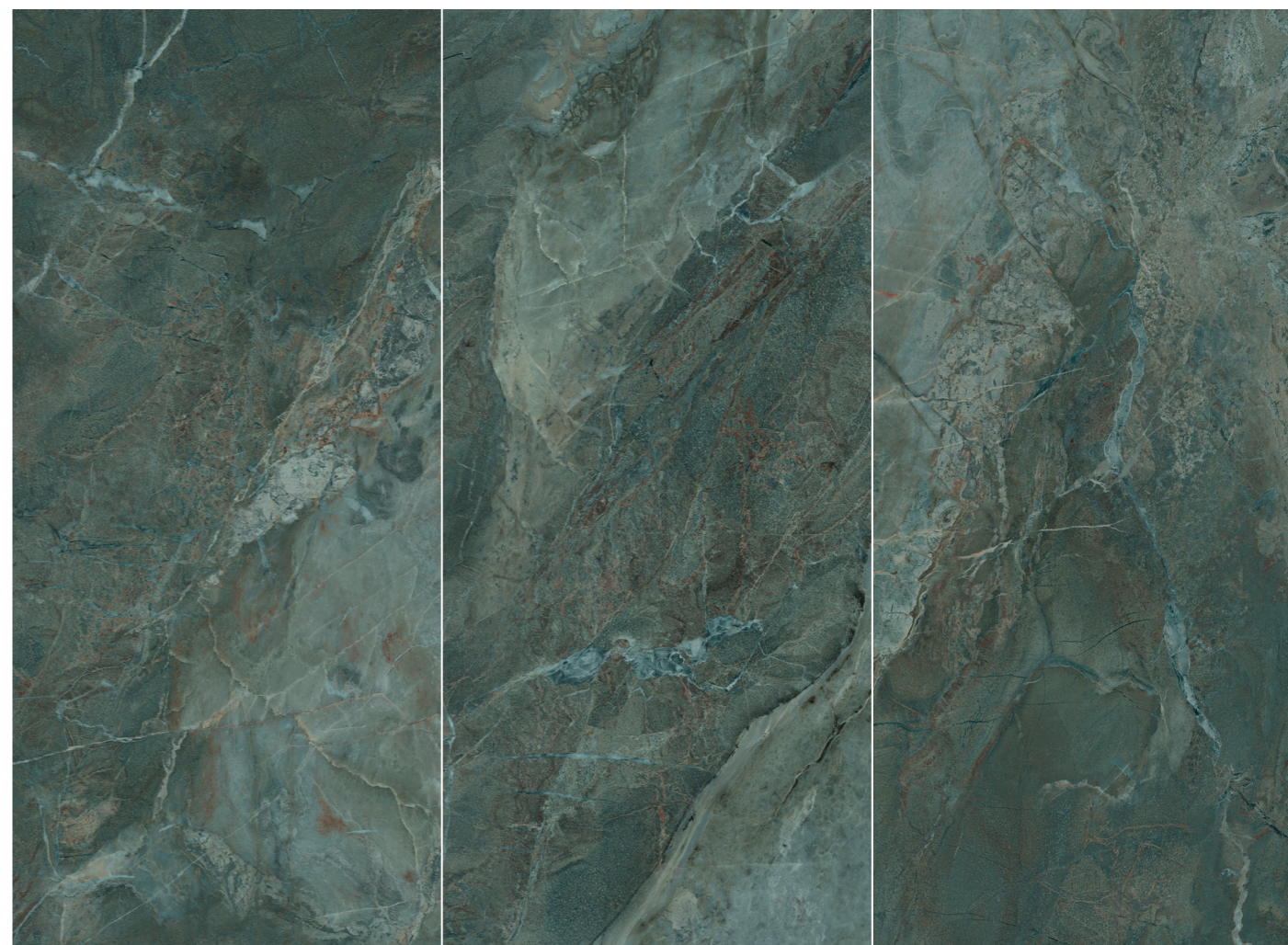

Dostupni formati:

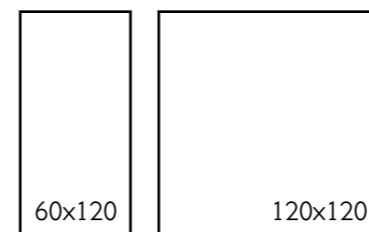

 Made in SPAIN	Kod	Format (cm)	Debljina (mm)	Površina	Pločica u kutiji	m <sup>2</sup> po kutiji	Kg po kutiji	Kutija na paleti	m <sup>2</sup> na paleti	Kg na paleti
	M230	120x260	7	Polirna	1	3.12	52	18	56.16	936





120 x 260  
Storm White mat

# 55

## Storm White

mat

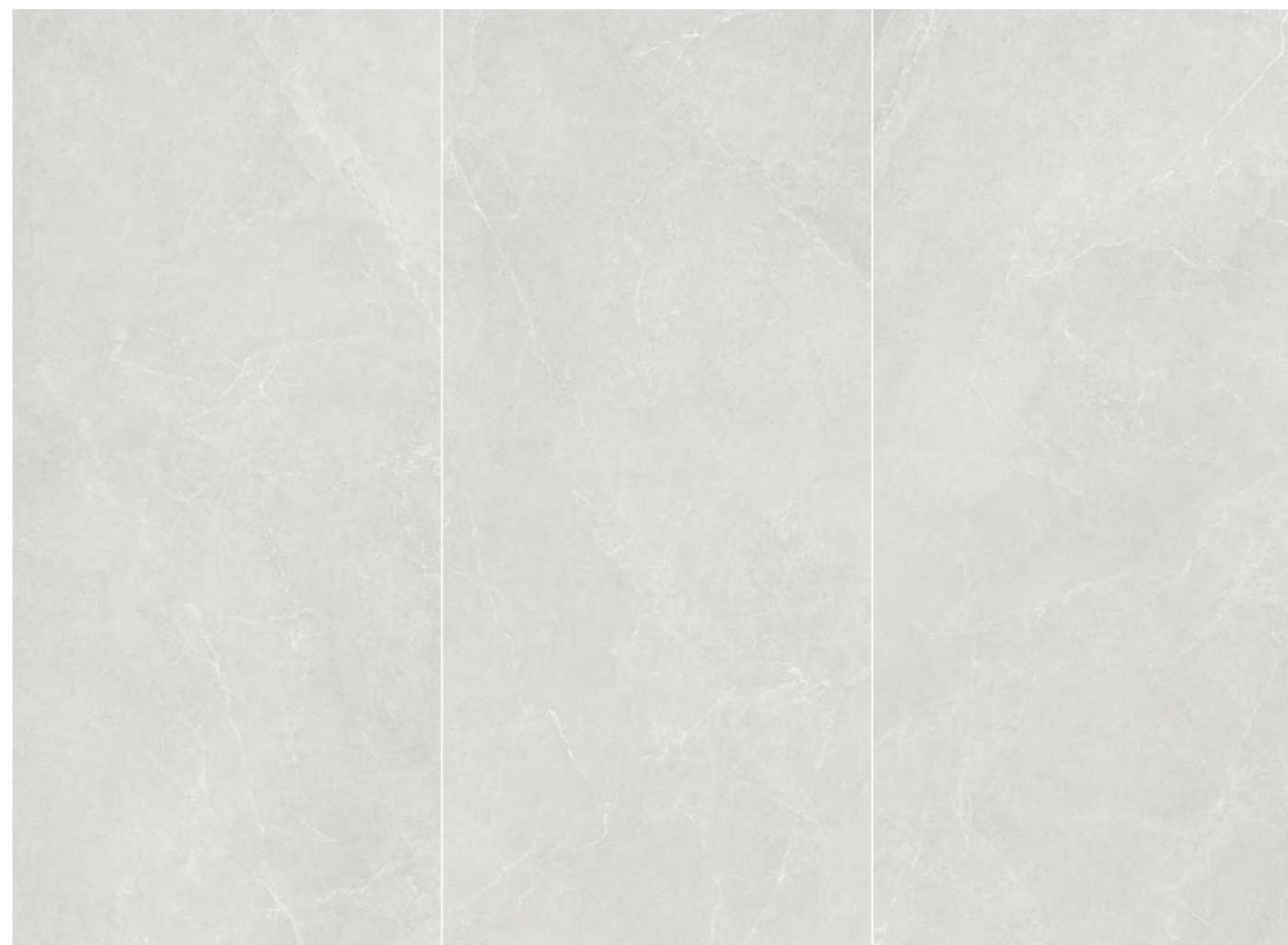

Dostupni formati:

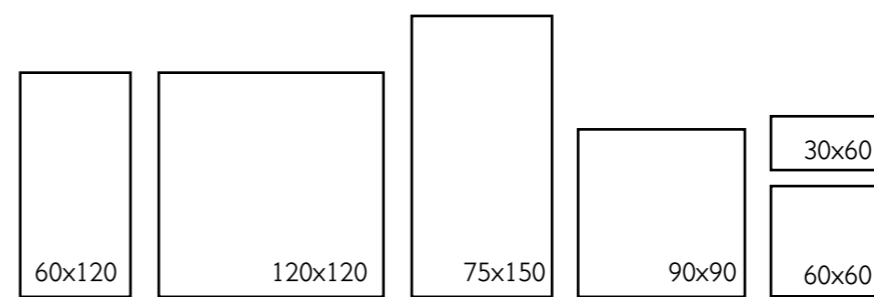

 Made in SPAIN	Kod	Format (cm)	Debljina (mm)	Površina	Pločica u kutiji	m <sup>2</sup> po kutiji	Kg po kutiji	Kutija na paleti	m <sup>2</sup> na paleti	Kg na paleti
	M220	120x260	6	Mat	1	3.12	43.8	24	74.88	1.171





120 x 260  
Storm Cloud mat

# 56

## Storm Cloud

mat



Dostupni formati:

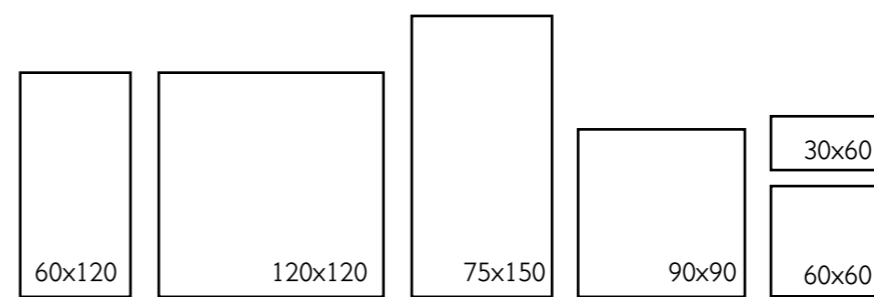

 Made in SPAIN	Kod	Format (cm)	Debljina (mm)	Površina	Pločica u kutiji	m <sup>2</sup> po kutiji	Kg po kutiji	Kutija na paleti	m <sup>2</sup> na paleti	Kg na paleti
	M220	120x260	6	Mat	1	3.12	43.8	24	74.88	1.171





120 x 260  
Storm Grey mat

# 57

## Storm Grey

mat



Dostupni formati:

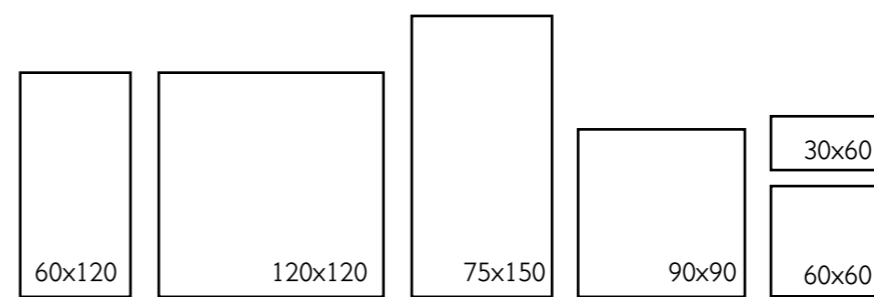

 Made in SPAIN	Kod	Format (cm)	Debljina (mm)	Površina	Pločica u kutiji	m <sup>2</sup> po kutiji	Kg po kutiji	Kutija na paleti	m <sup>2</sup> na paleti	Kg na paleti
	M220	120x260	6	Mat	1	3.12	43.8	24	74.88	1.171





# 58

## Storm Cream

mat



Dostupni formati:

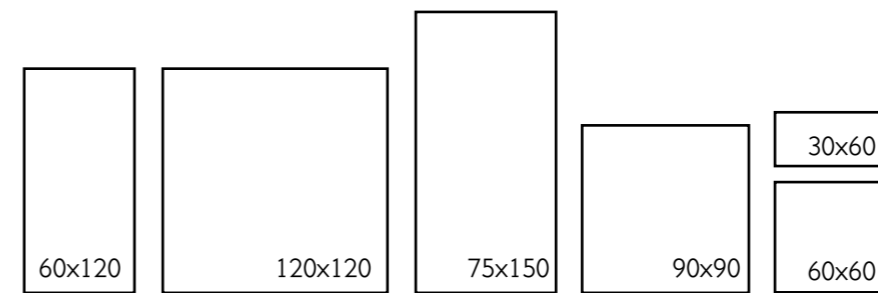

120 x 260  
Storm Cream mat

 Made in SPAIN	Kod	Format (cm)	Debljina (mm)	Površina	Pločica u kutiji	m <sup>2</sup> po kutiji	Kg po kutiji	Kutija na paleti	m <sup>2</sup> na paleti	Kg na paleti
	M220	120x260	6	Mat	1	3.12	43.8	24	74.88	1.171





# 59

## Storm Earth

mat



Dostupni formati:

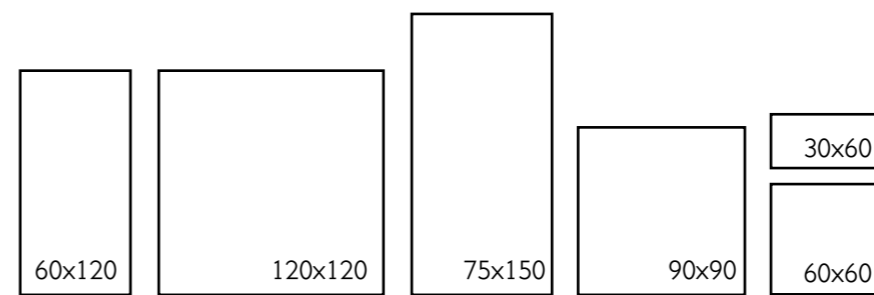

120 x 260  
Storm Earth mat

 Made in SPAIN	Kod	Format (cm)	Debljina (mm)	Površina	Pločica u kutiji	m <sup>2</sup> po kutiji	Kg po kutiji	Kutija na paleti	m <sup>2</sup> na paleti	Kg na paleti
	M220	120x260	6	Mat	1	3.12	43.8	24	74.88	1.171





120 x 260  
Moher Nut mat

# 60

## Moher Nut

mat



Dostupni formati:

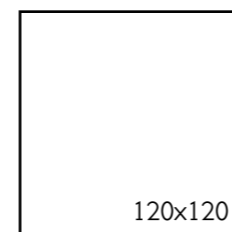

 Made in SPAIN	Kod	Format (cm)	Debljina (mm)	Površina	Pločica u kutiji	m <sup>2</sup> po kutiji	Kg po kutiji	Kutija na paleti	m <sup>2</sup> na paleti	Kg na paleti
	M220	120x260	6	Mat	1	3.12	43.8	24	74.88	1.171





120 x 260  
Moher Ash mat

# 61

## Moher Ash

mat

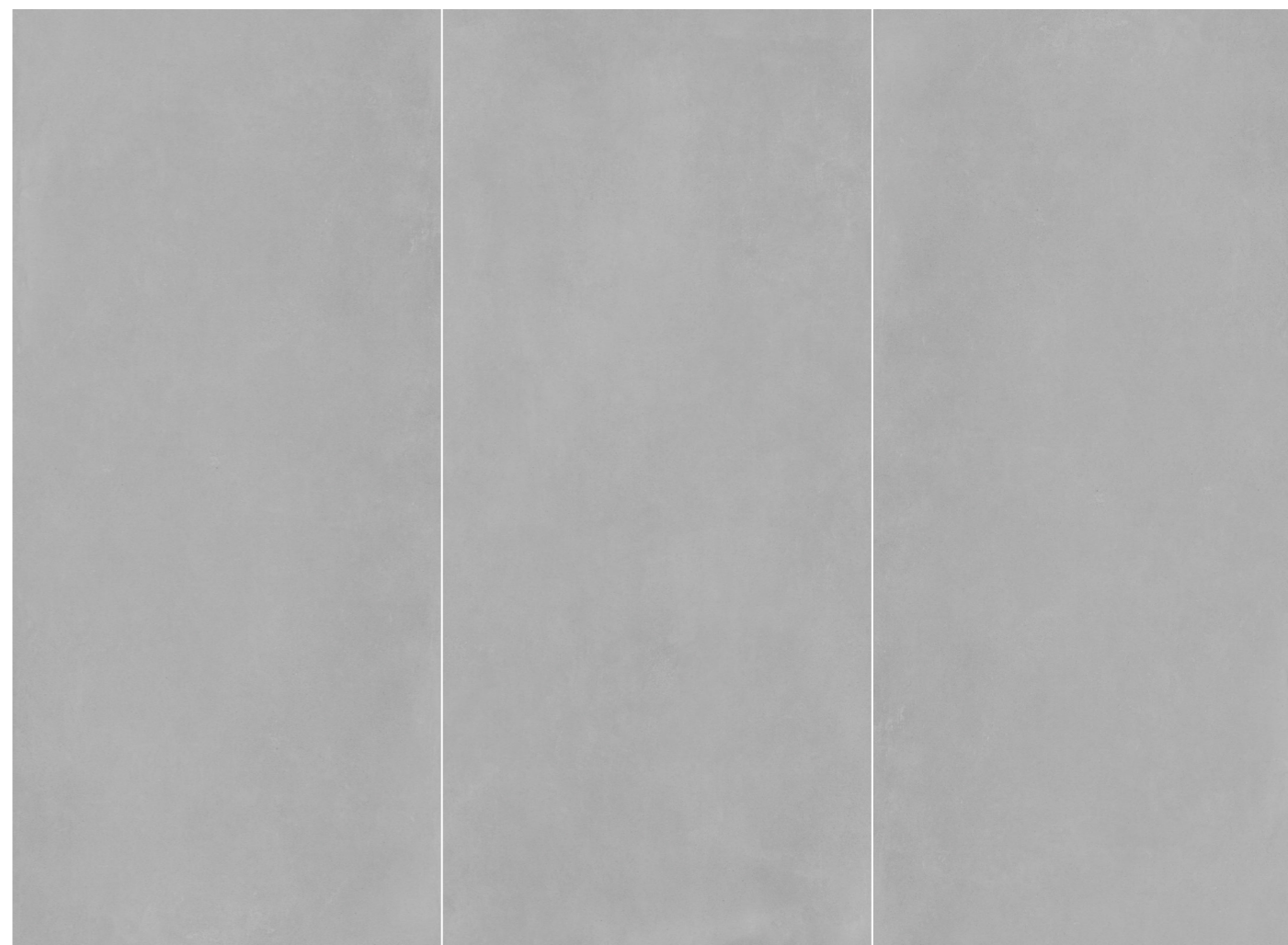

Dostupni formati:

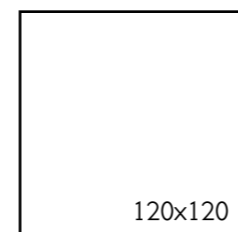

 Made in SPAIN	Kod	Format (cm)	Debljina (mm)	Površina	Pločica u kutiji	m <sup>2</sup> po kutiji	Kg po kutiji	Kutija na paleti	m <sup>2</sup> na paleti	Kg na paleti
	M220	120x260	6	Mat	1	3.12	43.8	24	74.88	1.171





# 62

## Moher Albar

mat

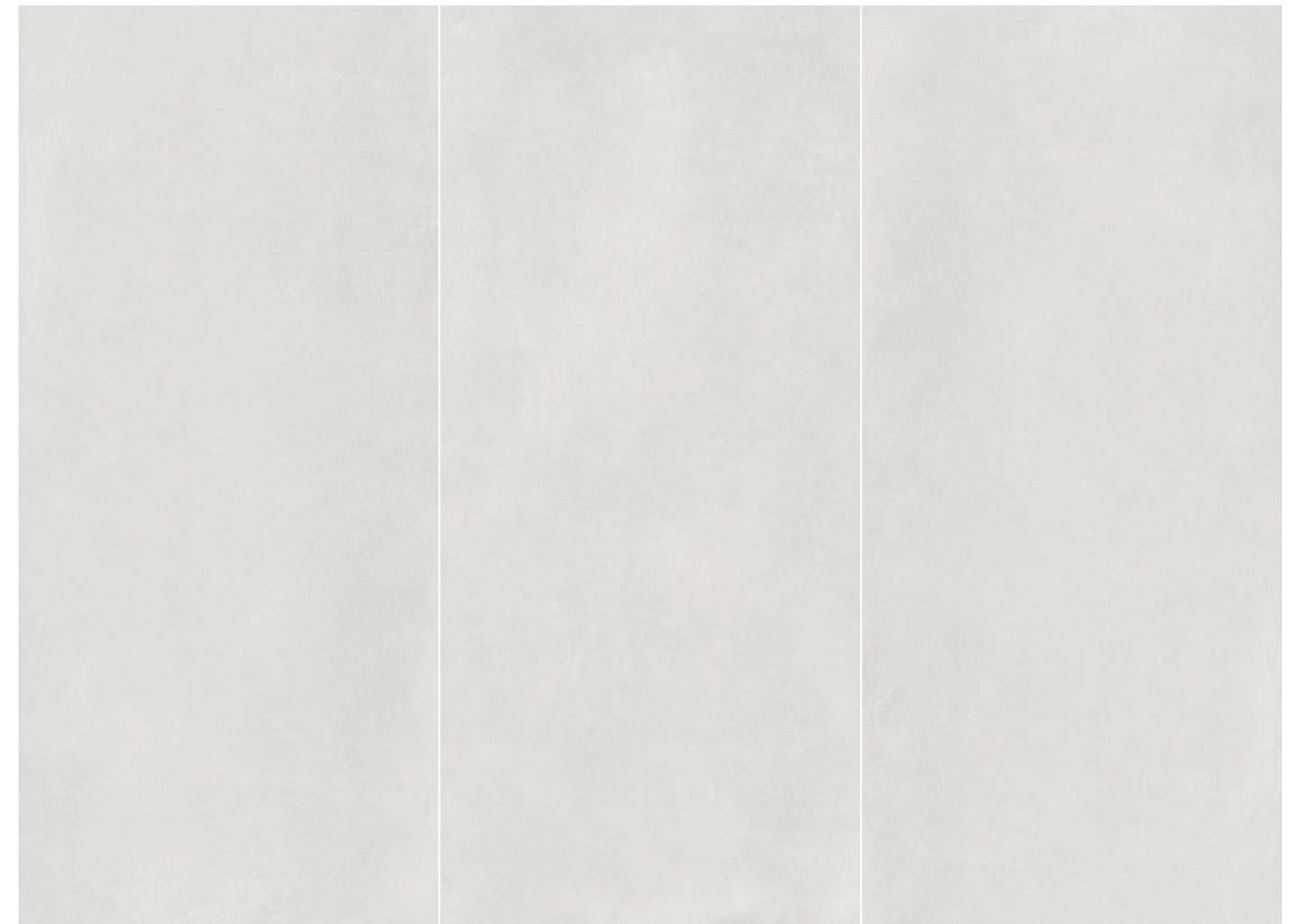

Dostupni formati:

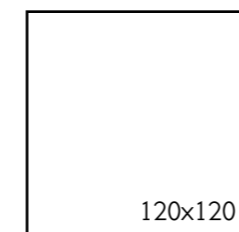

120 x 260  
Moher Albar mat

 Made in SPAIN	Kod	Format (cm)	Debljina (mm)	Površina	Pločica u kutiji	m <sup>2</sup> po kutiji	Kg po kutiji	Kutija na paleti	m <sup>2</sup> na paleti	Kg na paleti
	M220	120x260	6	Mat	1	3.12	43.8	24	74.88	1.171



# PREPORUKE ZA UGRADNJU

## 01 ///

### TRANSPORTOVANJE PLOČICA VELIKIH FORMATA

Za utovar, transport i istovar pomoću viljuškara ili paletne dizalice, viljuške moraju biti ubačene do minimalne dužine od 1,3 m sa minimalnim razmakom od 80 cm, kroz najdužu stranu.

Ako je paleta podignuta za utovar u kontejner kroz kratku stranu, mora se koristiti razmak od 80 cm i viljuške dužine 2,5 m.

Prilikom utovara i istovara potrebno je sprečiti udarce i oštre pokrete koji mogu imati negativan efekat.

Zbog svojih dimenzija, potrebno je voditi računa o tome da uslovi transporta keramičkih pločica budu odgovarajući kako bi se sprečilo moguće zatezanje i buduće lomljenje.

Prilikom istovara i utovara prenosi se samo jedan paket istovremeno!

Zbog toga je preporučljivo dati informacije o sadržaju paleta i dati odgovarajuća uputstva.

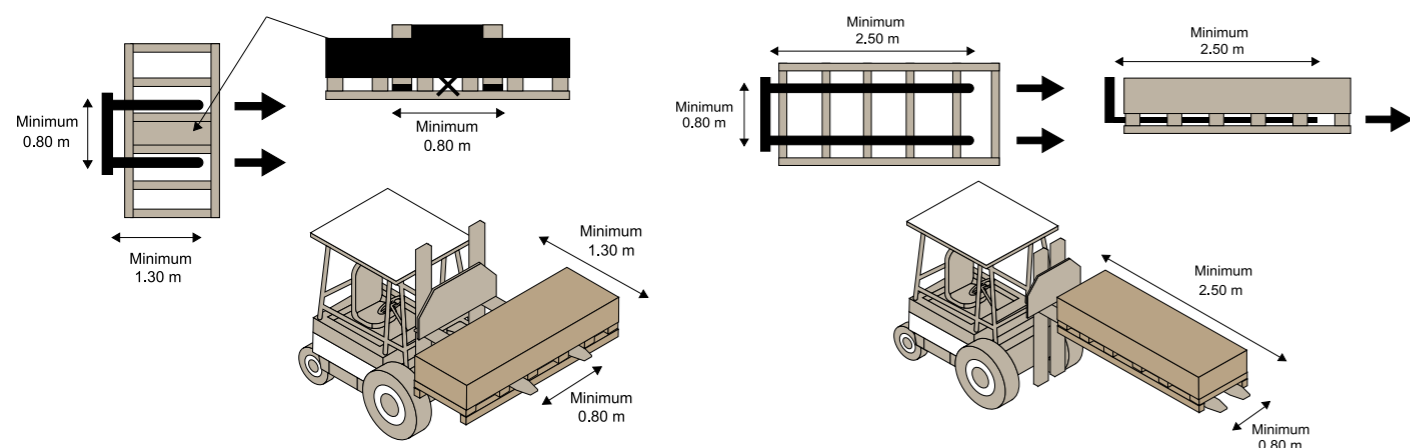

## 02 ///

### RUKOVANJE KERAMIČKIM PLOČICAMA

U uslovima eksploatacije, nakon ugradnje, Grande keramička pločica obezbeđuje iste performanse u smislu snage i otpornosti kao i konvencionalne pločice.

Međutim, zbog svoje veličine, 120x280 i 120x260, a i debljine, rukovanje i skladištenje keramičke pločice zahteva mere predostrožnosti i tehnike koje su različite od rukovanja pločicama manjih formata.

Ovaj priručnik se uvek odnosi na rukovanje celim keramičkim pločicama.

Keramičkim pločicama koje se isporučuju u formatima manjim od 1 m<sup>2</sup> može da rukuje jedan radnik.

#### 2.1 SKLADIŠTENJE KERAMIČKIH PLOČICA

Nakon isporuke i skladištenja materijala na lokaciji, moraju biti pravilno uskladišteni i raspoređeni po spratovima ili radnim jedinicama pre instalacija.

Položaj paleta se mora proučiti kako bi se mogle locirati što je bliže moguće površini na koju se postavljaju kako bi se obezbedilo dovoljno prostora za rukovanje.

Nakon što su keramičke pločice isporučene iz fabrike, preporučuje se (posebno za polirane pločice) da ih postavite vertikalno na tlo, stojeći na najdužoj strani, pod uglom od 30° odnos prema zidu.

Za zaštitu ivica i uglova keramičkih pločica preporučujemo postavljanje neklizajućeg, mekanog materijala između poda i jedinica.

Takođe ih je moguće uskladištiti horizontalno. U tom slučaju morate biti sigurni da je podloga potpuno ravna i da je površina svih pločica potpuno čista tako da površina ne bude oštećena.

#### 2.2 RUČNO RUKOVANJE KERAMIČKIM LAMINATNIM PLOČICAMA

Zbog svoje veličine i debljine, keramičkim pločicama se mora rukovati uz posebnu pažnju.

Njima se može manipulirati ručno ili sa vakuumskim prenoslačem za staklo ili keramiku ili ramovima sa usisnim prenoslačem da bi to učinili bezbednije.

Prilikom rukovanja sa keramičkim pločicama neophodno je nositi neklizajuće zaštitne rukavice za staklo i zaštitnu obuću.

Tokom rada potrebno je držati kičmu uspravno.

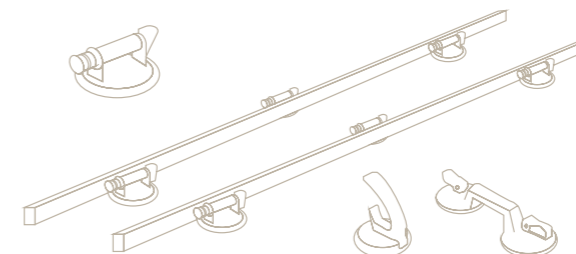

#### 2.3 PODIZANJE I RUKOVANJE KERAMIČKIM PLOČICAMA

Ako keramička pločica dolazi u formatu većem od 1 m<sup>2</sup>, sa njom mora da rukuje najmanje dva radnika.

Grande pločica se mora podići blagim podizanjem jedne od dve dugačke strane tako da je možete uhvatiti rukama.

Zatim se mora postaviti (pločica) vertikalno oslanjajući je prvo na ivicu duže strane. Kada je pločica vertikalna, mora se podići držeći je za gornji deo ivicu i držeći je stalno ravnom tokom kretanja. Da bi se pločica postavila na ravnu površinu, duža ivica pločice se prvo mora pažljivo podupreti. Onda druga osoba mora da drži sredinu pločice sa raširenim rukama. Pločica tada mora biti nežno oslonjena na ravnu površinu.

Prilikom nošenja i rukovanja keramičkim pločicama na licu mesta, preporučujemo korišćenje okvira sa vakuumskim prenoslačem namenjenih posebno za tu svrhu.

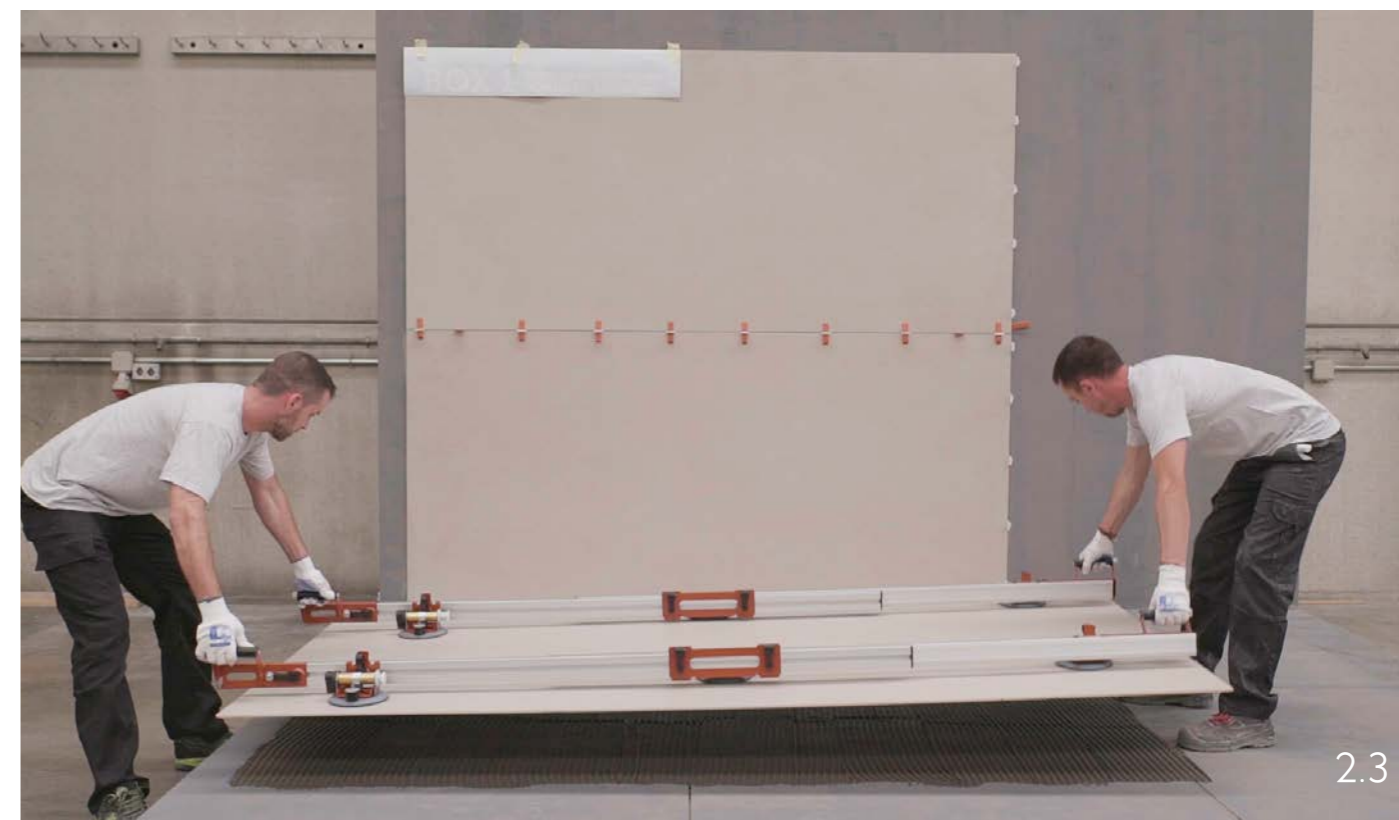



## 03 ///

### PLANIRANJE RADOVA NA POSTAVLJANJU KERAMIČKIH LAMINATNIH PLOČICA

Pre nego što započnete radove na postavljanju keramičkih pločica, morate planirati proces u cilju optimizacije performansi i obezbeđivanja ispravnih performansi i konačni kvalitet popločavanja.

Morate proceniti predviđene uslove životne sredine tokom procesa izgradnje i kako će oni uticati na nosače i lepkove, posebno pri postavljanju pločica na otvorenom.

Morate osigurati da ima dovoljno prostora za udoban rad sa keramičkim pločicama, stoga morate pripremiti radni sto za izvođenje operacije sečenja, bušenja i nanošenje lepka.

Takođe morate osigurati da ima dovoljno prostora za rukovanje pločicama zbog njihove velike dimenzije.

Morate proceniti stanje prostora koji će biti popločan, nosača i površine na koju se pločica postavlja.

#### 3.1 OBELEŽAVANJE POVRŠINE NA KOJU SE POLAŽU PLOČICE

Obeležavanje područja pre početka radova na montaži je neophodna operacija za tehnički kvalitet i izgled površine obložene keramičkim pločicama. Odgovarajuće obeležavanje svakog projekta pojednostavljuje rad sečenja, sprečava se potreba za zamenu i prilagodavanje, rešava probleme sa specifičnim delovima i spojevima, minimizira gubitke materijala, poboljšava performanse i izbegava asimetrije i netačne optičke efekte.

Obeležavanje se sastoji u odabiru šare spoja za pločice i njihova kombinacija ili raspored u određenom obliku.

Označavanje i raspored keramičkih pločica mora biti adekvatno obrađen u građevinskim planovima. Međutim, ako te informacije nisu detaljne ili nema građevinskih planova jer se radi o renoviranju treba uzeti u obzir sledeća uputstva.

Prostor za popločavanje mora biti obeležen kako bi se izbegle uske trake i da bi se optimizovala geometrija sečenja, a takođe treba i da se adekvatno nosi sa problemima u specifičnim oblastima.

Keramičke pločice se uglavnom postavljaju u velikim prostorima u kojima je format velike veličine posebno koristan.

Međutim, u veoma malim prostorima, poput kupatila, posebna pažnja se mora posvetiti planiranju obeležavanja, Bavljenje problematičnim područjima (vrata, prozori, stubovi, itd.) i posebno lokacija napravljenih rupa za priključke za vodu i druge armature.

Dizajn i dimenzionisanje pokretnih fuga u oblasti koja se postavlja pločicama moraju biti uključeno.

Redosled u kome će se postavljati pločice mora biti planiran kako ne bi zgazili već položene.

## 04 ///

### ALATI I OPREMA ZA POSTAVLJANJE KERAMIČKIH LAMINATNIH PLOČICA

Proces postavljanja keramičkih pločica zahteva opremu i alate slične onima koji se koriste za postavljanje bilo koje druge vrste pločica, kao što su nazubljene i druge vrste gleterki, gumene i druge vrste plovaka, sundere, lenjire, libele, podesivog kvadrata, nivelacionih šipki, mešalice lepka, brusilice, diskove, burgije itd.

Takođe zahteva drugu opremu, alate i mašine razvijene posebno za postavljanje keramičkih pločica velikih formata, kao što su alati za sečenje, pojedinačne vakuumske prenosake ili okvir za rukovanje sa vakuumskim prenosakom.

U svakom slučaju, specifična oprema i alati potrebni su da bi se Grande pločice pravilno uklopile.

Ne zahtevaju velika ulaganja montera i jesu jednostavane za korišćenje.

## 05 ///

### IZBOR LEPILA I FUGIRANJE

Zbog svojih tehničkih karakteristika i veličine, odabir lepka i fugovanje predstavljaju bitan faktor pri postavljanju keramičkih pločica velikih formata.

Moraju se odabrati lepkovi koji se koriste za postavljanje keramičkih pločica u skladu sa smernicama u tabeli 21 po standardu UNE 138002. Najmanje C2 S1 lepak mora da se koristi za keramičke pločice sa bočnom dužinom preko 70 cm bez vlakana na poledini kada ih postavljate na unutrašnje podove i zidove.

U slučaju popločanih fasada, podova sa podnim grejanjem i pločica sa vlaknima na poledini koje se koriste kao podne i zidne, treba izabrati lepak C2 S2. U svakom slučaju, zbog formata keramičkih pločica i potrebnog vremena za nanošenje lepka na podlogu, preporučljivo je uvek koristiti lepkove sa produženim otvorenim vremenom.

Prilikom postavljanja pločica sa vlaknima na poledini na popločanoj fasadi, morate koristiti lepkove tipa R2 koji su veoma deformabilni.

Kada su pločice sa zadnje strane ojačane mrežama i smolama, morate proveriti kompatibilnost tih materijala sa korišćenim lepkovima kako biste bili sigurni da će im odgovarati.

Materijale za fugiranje treba izabrati iz tabele 16 UNE 138002 standardne. Treba koristiti materijale tipa CG2. Kada moraju biti otporni na vodu i parootporni ili su pak za upotrebu u kupatilu ili odeljku gde se radi sa hranom, trebalo bi da budu izabrani materijali tipa RG.

## 06 ///

### INSTALACIONI SPOJEVI

Instalacioni spojevi su bitan element u proizvodnji konačnog kvaliteta, izdržljivost i dobrih performansi keramičkih pločica. Zbog velikog formata, instalacioni spojevi su još važniji kod postavljanja keramičkih pločica.

Instalacioni spojevi su fizičko razdvajanje između susednih keramičkih pločica. Oni su neophodni da bi pločice bile otpornije (oni pomažu da se apsorbiraju sile nastale nestabilnošću u osloncima i dimenzijama koje variraju u samoj pločici), da bi se povećao kapacitet difuzije pare, da bi se pomoglo vodi da isparava iz lepkova i omogućavalo da se pojedinačne pločice poprave i zamene.

Instalacioni spojevi takođe igraju važnu ulogu u izgled krajnjeg rezultata oblaganja pločicama.

Širina i raspored instalacionih spojeva moraju biti adekvatno obrađeni u planovima izgradnje. Međutim, ako te informacije nisu detaljne ili nema građevinskih planova jer se radi o renoviranju, sledeća uputstva treba uzeti u obzir.

Ni u kom slučaju površinu ne treba obložiti keramičkim pločicama bez spojnice ili sa dva spojena dela.

Preporučeni spoj za ugradnju, prilikom ugradnje Grande keramike punog formata, između pločica je minimalna širina od 3 mm u zatvorenom prostoru na stabilnim podlogama. Do 5 mm otvoreni spoj treba koristiti kada je navedeno u građevinskim planovima ili na nestabilnim podlogama, popločanim fasadama ili kada je u pitanju podno grejanje u određenim slučajevima.





## REZANJE, BUŠENJE I ZAVRŠNA OBRADA IVICA KERAMIČKIH PLOČICA

Keramičke pločice su veoma velike, ali tanje, te je relativno lako seći, bušiti i obrađivati ivice, bez potrebe za korišćenjem velike ili skupe opreme ili mašina. Međutim, u specifičnim projektima sa različitim potrebama formata, preporučuje se naručivanje jedinice prethodno isečene u fabrici.

U ostalim slučajevima, operacije sečenja, bušenja i završne obrade ivica mogu se vršiti na licu mesta uz odgovarajuću opremu.

### 7.1 REZANJE ALATOM ZA STAKLO

Operacije sečenja se mogu izvesti napolju sa alatima koji se koriste za sečenje stakla. Prednosti ove vrste sečenja su izuzetna čistoća, visoka preciznost i velika brzina. Preporučuje se da se prethodno izvrše neki testovi rezanja tako primenite ispravan pritisak na pločice.

### 7.2 REZANJE SA POSEBNIM ALATIMA

Postoje posebno alati razvijeni za sečenje za ovih vrsta pločice koje se odnose na suvo rezanja keramičkih pločica.

Ovi alati se mogu koristiti za izradu ravnih suvih rezova i dijagonalnih rezova svih vrsta. Da bi ste ih isekli, postavite keramičke pločice na radni sto, označite liniju sečenja, te postavite vodič na poziciju sečenja. Zatim ga označite sa točkicom za bodovanje. Da biste to uradili, označite početnu tačku i okrenite točak uz stalni pritisak i brzinu.

### 7.3 REZANJE DIJAMANT DISKOVIMA

Takođe je moguće izvesti suvo ili vodeno hladeno sečenje diskom koristeći ručne alate ili klupe za sečenje. U ovom slučaju, morate sa visokom brzinom obrtaja i malom brzinom obrtaja postići dobar rezultat. Ovaj sistem dozvoljava samo prave rezove. Za sečenje složenijih oblika neophodno je koristiti sečenje vodenim mlazom.



7.2



7.3

### 7.4 BUŠENJE RUPA

Za okrugle rupe morate koristiti bušilicu koja nije u režimu čekića. Preporučuje se hlađenje vodom na početku sečenja i započeti bušenje pri maloj brzini okretanja; ne naprezati sa prekomernim pritiskom. Možete izrezati rupe sa prečnikom manjim od 6 mm pomoću testera za rupe, koje se koriste za mašinsku obradu stakla, postavljene na (ručnu ili klupnu) bušilicu ili sa vodenim mlazom.

### 7.5 BRUŠENJE I ZAVRŠNA OBRADA IVICA

Brušenje i obrada ivica mogu biti sprovedene na različite načine sa različitim nivoima preciznosti. Mašine namenjene za završnu obradu staklenih ploča mogu se koristiti sa istim rezultatima u pogledu brušenja i završne obrade za keramičke pločice. Dobri rezultati se mogu postići sa mašinom i alatima za mašinsku obradu prirodnog kamena, iako sa nižim kvalitetom završne obrade.



7.4



7.5



## POSTUPAK POSTAVLJANJA KERAMIKE

Postupak koji se koristi za postavljanje Grande keramičkih pločica zasniva se na materijalu i tehnologiji ugradnje keramičkih pločica. Dakle, profesionalan keramičar sa obukom i iskustvom treba da bude odgovoran za njihovo postavljanje prilagodbom tehnike uklapanja karakteristikama i dimenzijama keramičke pločice.

U cilju stvaranja kvalitetne tehničke završne obrade i izgleda (sa keramikom), morate izvršiti postupak postavljanja na odgovarajući način u skladu sa ovim uputstvima:

### 8.1 ČIŠĆENJE KERAMIČKIH PLOČICA

Dobro je prvo očistiti pozadinu pločica, odnosno ukloniti vlakna koja su ostala tokom proizvodnje i rektifikovanja. Ako se vlakna nalaze na poledini, čišćenje je neophodno za uklanjanje tragova lepka i drugih materijala. Oni mogu formirati površinski sloj koji čini postupak lepljenja pločica težim.

### 8.2 NANOŠENJE LEPKA NA POLEDJINU

Prvo nanosite lepak na poledinu pločice. Lepak prvo treba da bude raspoređen po ravnom delu gleterice a zatim četkajte u pravoj liniji, upravno na prethodnu postavljenu pločicu. Generalno se preporučuje gleterica od 8 mm.

Veoma je važno sprovesti ovu operaciju što brže kako lepak ne bi bio otvoren duže nego što je preporučljivo maksimalno otvoreno vreme lepka.

Zapamtite da je površina jedna jedinice keramičkih pločica 3,12 m<sup>2</sup>.

### 8.3 DVOSTRUKA METODA LEPLJENJA

Drugo, nanosite lepak na poledinu keramičke pločice za dvostruko lepljenje. Ovo se može nositi van sa glatkim delom gletericama tako da cela zadnja strana keramičke pločice bude obložena tankim slojem lepka.

Primena dvostrukog lepljenja ne sme premašiti preporučenu debljinu lepljivog sloja koju preporučuje proizvođač. Metoda dvostrukog lepljenja se mora primeniti prilikom postavljanja keramičkih pločica u cilju optimizacije vlažnost poledine pločice i stvaranja homogenog kontakta na celoj površini sa tankim slojem dobro zbijenog lepka.



8.2



8.3

### 8.4 POSTAVLJANJE KERAMIČKIH PLOČICA

Postavite pločice na podlogu nakon nanošenja lepka na njihovu poledinu (keramičke pločice). Prvo morate pogledati da li postoje prepreke koje sprečavaju ispravno rukovanje pločicom od rada stola do konačnog položaja. Ova operacija se mora izvršiti timom od najmanje dva radnika.

Zapamtite da keramička pločica ima ukupnu težinu od 45 kg plus težina dvostrukog lepljenja lepaka. Rukovanje pločicom na radnom stolu se može izvršiti ručno ili odgovarajućim okvirom sa vakumskim nosačima. Koordiniran rad tima montera je važan da bi se postavile pločice što je bliže moguće do svog konačnog položaja.

### 8.5 NAKON POSTAVLJANJA KERAMIKE

Kada je keramika postavljena i lepak je još svež, pločica se može kucati da bi se prilagodila svom konačnom položaju i da bi se osiguralo da je lepak dobro zbijen. Kada je pločica u finalom položaju, odvajanje od susednog komada se podešava sa odstojećima.

Višak lepka mora biti očišćen od instalacionih spojeva pre susenja lepka.

Lepak mora biti zaštićen od brzog sušenja i vlage.



8.4

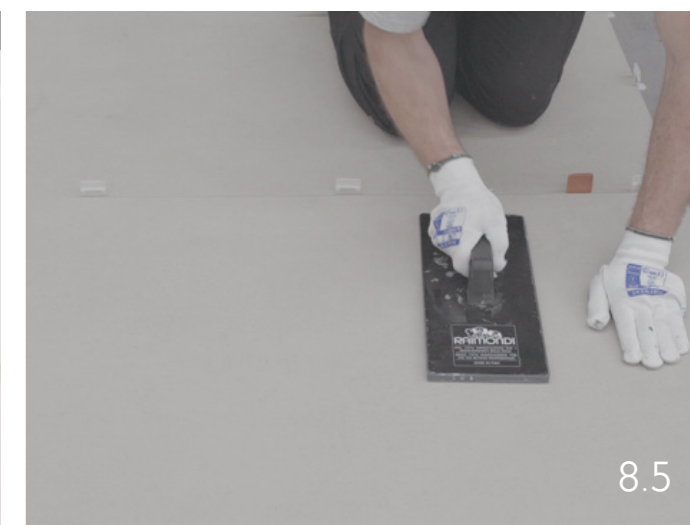

8.5

### 8.6 UPOTREBA SISTEMA NIVELA

Za pravilno postavljanje keramike moraju se koristiti sistemi za nivelisanje pločica kako bi se postigla optimalna ravnost, sprečilo da pločice štrče, razlike u nivou il razlike u gradijentu između jedinica.

Kada je keramika pravilno postavljena i zbijena u svom konačnom položaju, ubacite osnove sistema za nivelisanje sa odvajanjem na koje ukazuje proizvođač.

### 8.7 PROCES FUGOVANJA

Fugovanje je izuzetno važno za krajnji rezultat keramičkog popločavanja u oba pogleda, tehničkog aspekte i dobro izgleda. Fugiranje se mora izvršiti pomoću materijala posebno razvijenih za tu svrhu, kako je definisano i klasifikovano po standardu UNE EN 13888.

Preporučuje se čekanje dokle god je moguće pre fugiranja pločica.

Spojevi moraju biti suvi. Nanesite fugu prema uputstvu proizvođača.

Fug masa se mora razmazati odgovarajućim gumenim sundjerom.

Morate čekati vreme koje navodi proizvođač pre početka prve operacije čišćenja.



# Tehnički podaci

Grupa : BI-a	Standard	Zahtevi: Standard EN 14411	Prosečna vrednost
Dimenzije i kvalitet vidljive površine	ISO 10545-2	Merenje dimenzija	Ispunjava norme
Upijanje vode	ISO 10545-3	Prosečna vrednost	<0.5%
Određivanje modula loma pri savijanju i čvrstoće pri lomu	ISO 10545-4	Modul loma	35-45 Nmm <sup>2</sup>
		Čvrstoća pri lomu	1600-2400 N
Otpornost na površinsko habanje	ISO 10545-6	Površinsko habanje	<130mm <sup>3</sup>
Otpornost na temperaturni šok	ISO 10545-9	Temperaturni šok	Otporne
Otpornost na mraz	ISO 10545-12	Rezultat	Otporne
Otpornost prema hemikalijama	ISO 1054513	Amonijum-hlorid 100g/L	Klasa A
		Natrijum-hipohlorit 20g/L	Klasa A
		Hlorovodonična kiselina 3%	Ispunjava norme
		Limunska kiselina 100g/L	Ispunjava norme
		Kalijum-hidroksid 30g/L	Ispunjava norme
		Sredstvo u lakom ulju koje stvara mrlje	5
Otpornost prema stvaranju mrlja	ISO 10545-14	Jod, rastvor u alkoholu	5
		Maslinovo ulje	5

## Cenovne grupe

Format	Mat	Polirano
120x280	M220	M230
120x260	M220	M230

## Legenda simbola

 PODNA | ZIDNA PLOČICA

 SJAJNA POVRŠINA

 MAT POVRŠINA

 POLIRANE PLOČICE

 POLUMAT I POLUSJAJ

 REKTIFIKOVANE PLOČICE

 OTPORNOST NA MRIZ | GRANITNE PLOČICE

 RAZNOLIKOST U DIZAJNU LICA PLOČICA

Neke kolekcije pločica, sadrže varijacije u dizajnu, čineći da pločice deluju međusobno različito, ali njihovim postavljanjem formiraju jedinstvenu celinu.

Stručno lice (keramičar) mora detaljno proveriti proizvod pre instalacije: tonove, kalibar i eventualne defekte.

BALKANIA CERAMICS D.O.O neće uvažavati reklamacije nakon postavljanja pločica.

\*Boje i tonovi slika u ovom katalogu su reference stvarnih modela. BALKANIA CERAMICS D.O.O ne preuzima odgovornost za greške pri štampanju bilo kog segmenta kataloga. BALKANIA CERAMICS D.O.O zadržava pravo da modifikuje, u skladu sa promenama na tržištima, bilo koji model, karakteristike ili druge informacije o svojim proizvodima bez odgovornosti ili bilo kakve obaveze.



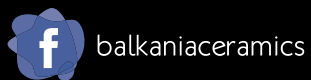
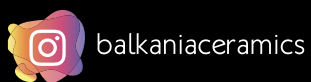

Balkania Ceramics d.o.o

Pančevački put 148  
11060 Beograd, Srbija

Tel: +381 11 33 270 33  
[info@balkaniaceramics.com](mailto:info@balkaniaceramics.com)